

ROYLER BARBECUE PIT MODEL 700E/ 1300E

OPERATIONS AND SERVICE MANUAL



J&R MANUFACTURING
820 W. Kearney
Suite B
Mesquite, Texas 75149

(972) 285-4855 (Texas)
(800) 527-4831 (50 states & Canada)
(972) 289-0801 (Parts and Service)
(972) 288-9488 (Fax)

⚠️ ADVERTENCIA

Leer y comprender el Manual de operaciones y servicio antes de usar esta máquina.

El incumplimiento de las instrucciones de operación podría causar lesiones graves o daño al equipo.



⚠️ WARNING

Read and understand operations and service manual before using this machine.

Failure to follow operating instructions could result in personal injury or damage to equipment.

⚠️ ADVERTENCIA

Riesgo de explosión

1. Nunca utilizar químicos volátiles como líquido para encender carbón, gasolina, grasa, etc., para encender o ayudar a prender un fuego. Nunca utilizar gas (natural o propano). Utilizar únicamente leña o ayudas que sean sólidas (poco volátiles) para encender el fuego.
2. Siempre deberá "RETIRARSE" por lo menos un minuto antes de abrir cualquier puerta para evitar retrocesos de la llama.



⚠️ WARNING

Explosion hazard

1. Never use volatile chemicals such as charcoal lighter fluid, gasoline, grease, etc. to start or aid fire. Never use gas (natural or propane). Use only kindling or safe (low volatility) solid fire starting aids.
2. Always "EVAC" for at least one minute before opening any door to avoid flashbacks.

SN _____

WARNINGS!

Disposal of Ashes

Ashes should be placed in a metal container with a tight-fitting lid. □□R offers ash carts suitable for this purpose. The closed container of ashes should be placed on a noncombustible floor or on the ground, well away from all combustible materials, pending final disposal. If the ashes are disposed of by burial in soil or otherwise locally dispersed, they should be retained in the closed container until all cinders have thoroughly cooled.

Creosote – Formation and Need for Removal –

When wood is burned slowly, it produces tar and other organic vapors, which combine with expelled moisture to form creosote. The creosote vapors condense in the relatively cool chimney flue of a slow-burning fire. As a result, creosote residue accumulates on the flue lining. When ignited this creosote makes an extremely hot fire. The chimney connector and chimney should be inspected at least twice monthly to determine if a creosote buildup has occurred. If creosote has accumulated it should be removed to reduce the risk of a chimney fire.

Dedicated flue

If this unit is to be directly vented (no exhaust hood) do not connect to a flue serving another appliance.

DANGER-Risk of Fire or Explosion

Do not burn garbage, gasoline, drain oil or other flammable liquids

WARNING-Risk of Fire

Do not operate with flue draft exceeding 0.03 in. water column.
Do not operate fuel loading or ash removal doors open.
Do not store fuel or other combustible material within marked installation clearances.
Inspect and clean flues and chimney regularly

If the oven temperature reaches 450 degrees F, a high limit thermostat will temporarily interrupt the temperature control function (it will automatically resume when it cools down). If this occurs (or if the indicating thermostat shows an abnormally high temperature) and the front doors feel excessively hot, **DO NOT OPEN THE DOORS**, as there may be a grease fire inside. Open the doors only after it cools down. Contact your supervisor (if applicable) while continuing to observe the pit. If you observe any flames, or perceive any fire threat, immediately contact the local fire department.

CAUTION-Hot Surfaces

Keep children away.
Do not touch during operation.

OYLER

BARBECUE PIT

MODELS 700E AND 1300E

OPERATIONS AND SERVICE MANUAL



MANUFACTURED BY:

J & R MANUFACTURING

CONTENTS

MODEL 700E/1300E COOKING MODES	1
INSTALLATION INSTRUCTIONS	4
OPERATING INSTRUCTIONS	13
MAINTENANCE AND CLEANING	16
TROUBLESHOOTING	19
FIGURE 1 – SUGGESTED INSTALLATION DIRECT VENT	24
FIGURE 2 – MODEL 700E DETAIL SHEET	25
FIGURE 3 – THROUGH THE WALL INSTALLATION DIRECT VENT	26
FIGURE 4 – MODEL 1300E DETAIL SHEET	27
FIGURE 5 – SUGGESTED INSTALLATION EXHAUST HOOD VENT	28
FIGURE 5A EXHAUST HOOD DESIGN	29
FIGURE 5B SMOKESTACK INSTALLATION	30
FIGURE 6 – COOKING MODE	31
FIGURE 7 –DAMPER ACTUATORS	32
MODEL 700E & 1300E WIRING SCHEMATICS – 240 VOLT	34
THERMOSTAT, ACTUATOR, AND TIMER MANUALS	38
WARRANTY	51

OYLER BARBECUE PIT

MODEL 700E / 1300E

COOK MODES

The “E” version of the Oyler Barbecue Pit Model 700/1300 uses electric heating elements in addition to wood fuel for the cooking heat source. Additional controls allow the operator to cook in one of two “Cook” Modes, “Standard” or “Dual Fuel”. In addition, a “Cook and Hold” feature can be utilized in either mode. The basic operation and use of the Oyler Barbecue Pit has not been altered. The control design of this unit incorporates the same basic operation sequencing of the standard 700/1300 series. Therefore, the basic **Operating** and **Maintenance Instructions** apply and should be referred to.

STANDARD COOK MODE

Operation of the 700/1300 “E” Barbecue Pit in this mode is the same as described on page 8 under the paragraph titled “Start Up”.

Turn the black **“COOK/OFF-COOK/HOLD”** switch to the “COOK” position. The yellow **“EVAC”** switch should be in the “ON” position and the **“HTR.ELM”** switch should be in the “OFF” position. Build a fire in the firebox using fresh cut hardwood.

Please note: using the **“EVAC”** MODE WILL ACCELERATE THE ESTABLISHMENT OF A FIRE IN THE FIREBOX. Once an adequate fire has been established in the firebox, turn the **“EVAC”** switch to the “OFF” position and set the thermostat to the desired cooking temperature. For best results, allow the pit to preheat prior to loading the product.

DUAL FUEL MODE

This mode allows the use of electric heating elements in addition to wood fuel. Please note: the convection fan is engaged continuously in this mode, so overall cooking times will be reduced.

Preheat pit in the “Standard Mode”. Load product and allow the pit to return to the desired cooking temperature. Once the unit has reached desired cooking temperature, turn the **“HTR.ELM”** switch to the “ON” position. A time delay built into the “Dual Fuel” circuitry will allow the wood fuel to be consumed first, utilizing the electric heating elements to “finish” the product. Used in this method, the operator can regulate the use of the heating elements (and wood fuel) in the cook cycle. A fully “stoked” firebox will delay (and may prevent) the use of the electric heating elements until late in the cook cycle. Consequently, a very small amount of wood fuel will bring on the elements much earlier. In either case the electric heating elements will guarantee that the thermostat set point will be maintained to the end of the cooking cycle.

Optional method for use in the “Dual Fuel” mode: Same as described above, except turn the red switch labeled **“HTR.ELM”** to the “ON” position at the **beginning** of the preheat operation. Using the pit in this method will allow the time delay for the electric heating elements to “time out” during preheat and the electric elements will be used simultaneously with the wood fuel from the beginning of the cook cycle.

COOK AND HOLD MODE

The difference between this mode and “Cook” mode (“Standard or “Dual Fuel”) is the temperature control is shifted away from the primary thermostat to a fixed secondary (or Hold) thermostat after the operator set timer, located on the instrument panel, counts down. To utilize this feature, simply switch the black **“COOK/OFF – COOK/HOLD”** switch to the “Cook/Hold” position and set the timer for the amount of time you wish the unit to remain in the “Cook” mode before going into the “Hold” mode. This feature can be utilized when cooking in either the “Standard” or “Dual Fuel” modes.

One point to remember when setting the timer, is that there is a slow “ramp-down” from the primary (initial) thermostat set point to the secondary (Hold) thermostat set point (non adjustable: fixed at 150° F). During this “ramp-down” the product will continue to cook, therefore, setting the timer for the same amount of time (cook cycle) that you would normally use will produce an over cooked product. The timer setting should be significantly reduced to compensate for this “ramp-down”. Some experimentation by the operator will be necessary to fine-tune the use of the “Hold” feature.

Example: Primary thermostat set at 200° F for cooking beef brisket. You might set the timer for 8 hours (assuming a 4 hour “Hold” period).

Please note: In the “Dual Fuel” mode the convection fan is engaged continuously. However, when control is shifted to the secondary (Hold) thermostat in the “Cook and Hold” mode the convection fan will cycle off each time the fixed thermostat reaches its set point.

IMPORTANT MAINTENANCE NOTE:

In addition to the maintenance procedures described elsewhere in this manual □the electric heating elements and the con□ection fan impeller should be inspected regularly □daily if possible □and cleaned if necessary □If there is a hea□y build up of soot or creosote □these surfaces should be cleaned with a stiff brush □This is especially important if the □Dual Fuel □mode is not used each cook cycle □Hea□y buildup on the elements can create a fire ha□ard □

NOTE :

Newer units with Idec "RTE" Timers:

Green "PWR" light will remain on, red "Out" light will illuminate when timer has timed out. For these timers the factory settings are mode: A, scale: 0-10, range: h.

Older units with Omron Timers:

Red light will illuminate, and green light will begin flashing, then the red and green lights will remain illuminated (steady, not flashing) when the timer times out. For these timers the factory settings are mode: A, time range: 12, time units: hours.

INSTALLATION INSTRUCTIONS

MODEL 700E AND MODEL 1300E

SHIPPING

The unit will be shipped fully assembled. A Model 700E will weigh 4,200 pounds and a Model 1300E will weigh 6,600 pounds. The meat racks will be packed inside the cooking compartment. If you ordered a smokestack kit, it will either be packed inside, or shipped on a separate pallet. There will be a grease drain valve packed inside the firebox, along with the firebox door handle. To move a Model 700E into your building, you will need a minimum opening of 60 inches in width and 83 inches in height (60" X 86"). For a Model 1300E, you will need a minimum opening of 72 inches in width and 92 inches in height (72"X 95"). The height requirements can be reduced by 3" by removing the damper actuator motors on the top of the unit.

HANDLING

A Model 700E can be handled with a forklift if the lift has a 6,000 pound capacity. A Model 1300E will require an 8,000 pound lift. The extra capacity lifts are necessary due to the size of the units. Whenever possible, the unit should be trucked from the rear. Alternatively, a crane can be used by rigging onto the four lifting lugs welded onto the top of the unit.

FOUNDATION

It is recommended that the unit be placed on a four to six inch thick concrete pad as shown on Figures 1, 3, and 5. This pad should be sized four inches larger than the pit in both dimensions (ex: Model 700 pad should be 59¾" by 108" (117" for a rear firebox)). This elevates the pit drain valve an additional four to six inches off the floor and facilitates grease handling. With a pad, the bottom of the grease drain valve would be nine to eleven inches off your finished floor versus five inches without a pad. We offer a four or six inch high, structural steel base frame to use in lieu of a concrete pad. Alternatively, you may use a shallow grease pan, pump the grease to your storage area, or pipe the grease to an adjacent location where an elevation difference would permit the use of a deeper pan. Use Figures 2 and 4 to locate the pit in your building so that the smokestack can be installed vertically with no offsets (avoiding building structural members). Whether a pad is used or not, **the pit must be installed on a solid, level, non-combustible surface.**

DRAIN

There is one drain connection on the pit. This drain is used for draining the grease and cleaning the cooking chamber. It extends from the side of the pit near the center and close to the bottom. Install the drain valve onto the threaded pipe nipple. If possible, a floor drain should be located near this drain valve as suggested in Figures 1, 3, and 5. This will be of convenience when the pit is being cleaned.

EXTERIOR INSTALLATION

There are two types of exterior installations. The unit can be placed entirely outside or you may wish to have only the front part of the unit inside your building. In either case, the unit should be painted and the top seams sealed for exterior installation. A non-combustible weather covering (awning, shed, etc.) must be installed over the portion of the unit that stands outside. Check with local health codes for details regarding the installation and use of an outdoor cooking device.

THROUGH THE WALL INSTALLATION

If this type of installation is selected (shown in Figure 3), we recommend that only the front 2.25 inches of the pit protrude through the finished wall surface to facilitate wall flashing/trim but to still allow access to the electrical junction box. The side access panel to the motor/gearbox will be blocked but all necessary access can be gained through the front access panel.

ELECTRICAL

The pit requires 240 volt, 1 phase, 70 amp electrical service. A switch or circuit breaker should be installed near the pit. It will be necessary during certain maintenance procedures to shut off the electrical supply to the pit. It is a good safety procedure to tag the switch to guard against someone inadvertently re-energizing the circuit. A junction box is secured to the top of the pit near the front (see Figures 1, 2, and 4). Your electrician should extend a conduit from the pit junction box to a 240 volt supply in your building using a grounded circuit. Please refer to your local electrical code for any other requirements.
CONNECT AT JUNCTION BOX ONLY.

CLEARANCES

The unit must be installed to conform to the following minimum clearances from any combustibles:

ABOVE TOP OF CASING	FROM FRONT	FROM BACK	FROM SIDES	FROM CHIMNEY CONNECTOR
12	48	6	6	6

The unit must be installed on a non-combustible floor.

Venting Requirements

Our barbecue ovens are listed under multiple standards, including U.L. 737 (Fireplace Stoves), U.L. 2162 (Commercial Wood-Fired Baking Ovens), and U.L. 391 (Solid-Fuel and Combination-Fuel Central and Supplementary Furnaces). These listing provide two alternatives for exhausting our units: direct venting and exhaust hood venting

In all cases, it is imperative to obtain the approval of the AHJ (Authority Having Jurisdiction). This will typically be the mechanical inspection department of the local municipality's building inspection division and/or the local fire marshal.

Option One: Direct Venting (Figures 1 and 3)

Our listings under U.L. 737 and U.L. 391 permit direct venting and the ventilation standard cited in each is NFPA 211 (Standard for Chimneys, Fireplaces, Vents, and Solid-Fuel Burning Appliances). All our enclosed ovens are designed to be vented via a smokestack (chimney) with natural draft. All models incorporate smoke-control (bypass) mechanisms to contain smoke spillage when the oven doors or firebox doors are opened.

In all cases in which combustible construction is present, a factory-built Type HT chimney is required (refer to NFPA 211 6.3.1.2 and U.L. 103). Examples of such chimneys would be Selkirk "Ultra-Temp" and DuraVent "DuraTech".

If no combustible construction is present (examples: exterior installations or installations in which the oven is faced into a non-combustible exterior wall and the chimney is either uncovered or covered with a non-combustible weather covering), then a single wall metal chimney (Figure 5B) is acceptable if approved by the AHJ.

The chimney should be a minimum of 10 feet in height (oven top to chimney top) and 14 to 18 inches in diameter. When possible, it should be straight (no offsets) and vertical. If this is not possible or practical, offsets and horizontal runs are permitted if it meets local codes and proper draft is achieved (see Air Balance). A fan may be required. This application falls under the classification of "Low Heat Non-Residential Appliance" with continuous outlet flue gas temperatures less than 1000 degrees F. The maximum draft is 0.03 inches water column, and a barometric draft regulator must be used if the draft exceeds that draft at full firing conditions. This can occur as an example when the chimney is very high as might be the case in multi-story buildings.

Air Balance

The building air balance is very important to the proper operation of your Oyler Pit. The Oyler design is based on the induction of air into the pit due to the “stack effect” of the chimney. The “stack effect” is the term used to describe the upward airflow created in a chimney based on the chimney height and the temperature difference between the bottom (inlet) and top (discharge). This “stack effect” induces airflow into the oven chamber via the front door opening (when the doors are open) and/or into the firebox when either the firebox door is open along with open bypass dampers or an open exit flue damper, or, if the firebox door closed, when the firebox combustion air damper is open.

Disruptions of this airflow can be caused by mechanical exhaust fans, buildings that are too airtight (insufficient openings for incoming air), and chimney downdrafts created by wind. Such downdrafts are often created by nearby windbreaks, which are taller than the chimney top. For this reason, the chimney should be four feet taller than the surrounding rooftop including nearby parapet walls, and taller than adjacent buildings and trees. If air balance cannot be achieved by normal means, you should consider using a fan to assist the stack effect. A fan on the terminus of a chimney can solve the problem. We recommend fans manufactured by Enerflex (www.enerflex.com) such as their Model GSV installed with a variable-speed controller. These fans are available through J&R and other sources.

Combustion Air

Make sure adequate combustion air is available. Excerpt from NFPA 211 12.3:

“Solid-fuel burning devices shall be installed in a location and manner so as to provide ventilation and combustion air supply to allow proper combustion of fuel, chimney draft, and maintenance of safe temperatures... where buildings are so tight that normal infiltration does not provide the necessary air, outside air shall be introduced.”

Option Two: Exhaust Hood Venting **(Figure 5)**

U.L. 2162 cites NFPA 96 (Standard for Ventilation Control and Fire Protection for Commercial Cooking Operations) as its ventilation standard. While NFPA 96 allows direct ventilation with factory-built grease ducts or properly constructed welded ducts (with fire-rated enclosures), it also permits the exhaust hood ventilation option for our units.

For proper design of a hood over our ovens, please refer to Figure 5A (Figures 5 and 5A depict a single canopy hood design).

It is **very important** that the filter bank be located toward the rear of the unit (near the chimney connector). This simulates the natural-draft of a chimney above the chimney connector for which these units were engineered to control both temperature and smoke.

The recommended exhaust volumes are based on the specifications from the 2009 International Mechanical Code Section 507.13.1 (Extra Heavy Duty Cooking Appliances, Single Canopy, 700 CFM per linear foot of hood). Wall-mounted hoods will require less volume (550 CFM per linear foot). These drawings specify a 12 inch hood overhang at the front oven doors and the side containing the fire box door with a 6 inch overhang on the non-active sides (no oven or firebox doors).

Notes:

- 1. Exhaust volume should be determined by the exhaust hood manufacturer based on their products listing and local code requirements. States such as California, Oregon, Washington, and Connecticut all have code driven maximum exhaust volumes for specific equipment. For example: California mandates that solid fuel exhaust hoods for a wall mounted application can use NO MORE than 385 cfm/lf for solid fuel.**
- 2. Spark arrestor type filters are required.**
- 3. Hoods serving solid fuel equipment must be dedicated to solid fuel only (no gas or electric) with their own dedicated fire protection system.**

Meat Racks and Hangers

Wire racks & hangers are shipped unassembled so that they may be used where required in the unit. They must be properly assembled before use to reduce the possibility of a rack jam.

When installing the racks and hangers, install the 12 hangers and 6 bottom racks first, and then install the upper racks.

Model 1300s

All Model 1300 rack hangers are “triple” (designed for a set of three racks per pair of hangers). Each hanger has three pairs of wire loops (see photo on the next page). Each rack will have corner “voids” through which the wire loops will be inserted. Hangers for older units (not shown) may have three pairs of ferrules instead of wire loops, and the racks associated with them will have rings in the corners through which the ferrules are inserted.

NOTE: YOU MUST ALWAYS have a rack installed in the lowest of the three positions of the hangers to avoid a rack jam.

Model 700s

The hangers for Model 700s will be one of the following:

Type 1. Triple hangers with three pairs of wire hooks per hanger. This is the style for all units manufactured from mid-2018 and later.

Type 2. (Older units). Triple hangers with wire hooks on the lowest level and slide rails for the middle and upper levels. For this style, you must follow the directions on the next page. The “nibs” on the middle and upper racks must be properly secured in the slide rails to prevent a rack jam.

Type 3. (Also, for older units). Double hangers with two pairs of hooks on each hanger. For this style you also must follow the directions on the next page.

NOTE: In all cases **YOU MUST ALWAYS** have a rack installed in the lowest position of the hanger to avoid a rack jam.

Model □00 Rac□



“Nib”

Model □300 Rac□

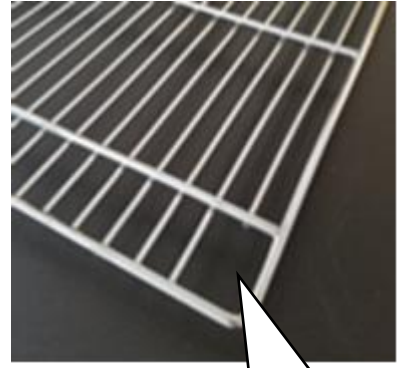

Corner void

These “nibs” (if present) must be removed (see below*) for all 700 hanger styles except for the middle and upper positions of Type 2 hangers.

* Remove the nib by using a large, adjustable wrench. Tighten the wrench jaws around the nib and bend the nib upward and downward until it snaps off.

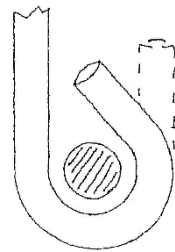
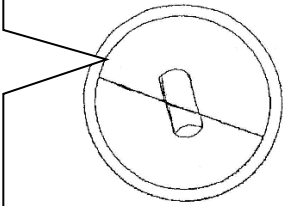

For hanger types 2 and 3 only, the lowest (bottom) pair of hooks on each hanger must be bent closed around the lower rack side rails.

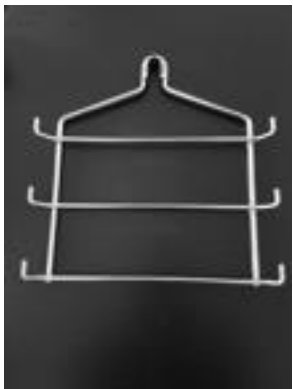

Model 700 Type 1



Model 700 Type 2

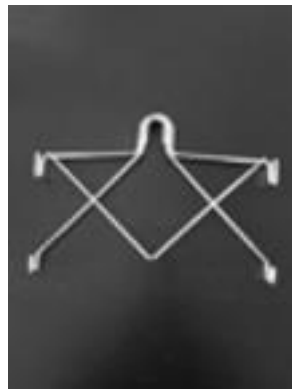

Model 700 Type 3

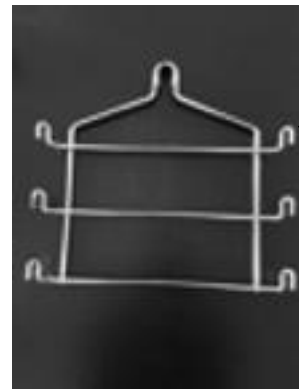

Model 1300

“Loop”

Additional information for Type 1 Hangers (For use with newer style racks (November 2018 and later))

Note:

This newer style rack does not require any modification (stainless steel zip ties) for proper hanger/rack alignment compared to older racks (see next page).



This newer rack style is differentiated from the older style by having additional bars at each end to align the hangers. The hanger hooks are placed inside the inner bars on each end.



Additional information for Type 1 Hangers (For use with older style racks (pre-November 2018))

Note:

For proper rack clearance and stability, this type of hanger (Type 1) must be secured to the lowest rack with a pair of stainless steel “zip” ties. This will be done at the factory for all new units using Type 1 racks. This step ensures proper clearance between the outside edges of the hangers and the rotisserie wheels.

For customers ordering replacement Type 1 hangers, we recommend that you also purchase a new style bottom rack (post-November, 2018, does not require zip ties). If you order the hangers separately (without a new style bottom rack), you will have to add the zip ties. Please refer to the photos below for proper installation. You can install the ties with a pair of needle nose pliers.*



Type 1 with older style bottom rack, front view



Type 1 with older style bottom rack, end view



Close-up of zip tie in place (older style rack)



Zip tie



Zip tie, partially tied

*You will need four zip ties. Hook the hangers into the proper positions on the rack. Place one tie between the third and fourth wires of the rack, both front and rear. Loop the tie around the hanger and the rack, insert one end of the tie into its receptacle, and pull it snug with pliers, making the final loop as small and tight as possible. Cut off the excess tie and “curl” the cut end with pliers so it poses no cut hazard.

OPERATING INSTRUCTIONS

MODEL 700E AND MODEL 1300E

START-UP

After the pit is installed, leveled, stacked, and connected to the electrical supply, check for proper operation:

(a) Turn the thermostat set point above and then below the actual temperature. The combustion air damper on the firebox should open and close. Open the access door at the rear of the pit and verify that the “exit flue damper” (see Figure 6) opens and closes in synchronization with the damper on the firebox door (note: if the internal temperature of the oven is below the lowest setting on the thermostat, these dampers will remain open).

(b) Energize the Rotisserie (or Roti) switch and push-in and hold the Rack Advance mushroom switch (green) – the racks should rotate. With the Rotisserie switch energized, the racks will rotate automatically when the front doors are closed and latched.

(c) Open the front doors or turn the “EVAC” switch on. Verify that the two large bypass dampers open (located over the firebox).

BUILDING A FIRE

NEVER USE CHARCOAL LIGHTING FLUID, GASOLINE, OR OTHER VOLATILE FUELS TO START THE FIRE. Load several small pieces of wood in the firebox. Open the front oven doors or turn the “Evac” switch on. This opens two dampers in the rear of the pit and allows the firebox to be vented directly to the smokestack. Hickory wood is recommended whenever available. Next in preference is oak or mesquite. Generally, however, any nut or fruit bearing hardwood would be acceptable. For best results, the wood should be relatively green (cut within two months). Start the fire by using kindling, or safe (low volatility) solid fire starting aids. As the fire becomes established, add more wood to the fire until the firebox is about one-half to three-fourths full. Since you will probably be cooking every day, subsequent fire starting will be much easier. Live red coals will last about two days in the firebox, so restarting a fire is simply accomplished by loading fresh wood onto these live coals. Wood should be 24 inches long and up to 8 inches in diameter (logs should be split if larger than 8 inches in diameter).

OPENING THE OVEN DOORS

If the pit is fired-up and operating and the front doors are closed, there will be dense smoke inside the oven. If you unlatch the doors and open them quickly, you will get a face full of smoke. Instead, first turn the thermostat down to close the Firebox damper and then turn the “Evac” switch on or slightly open the front doors causing the bypass dampers to open and begin venting smoke up the stack. Wait about 45 seconds (the slightly open doors will help evacuate smoke by allowing a fresh air entry path into the pit) and then slowly open the doors.

MEAT LOADING

The first time the pit is fired, it is recommended that you allow it to operate or several hours while empty. This allows any residues (oil, paper, etc. to be removed. After this is done, you may load meat onto the racks. **Take care when loading to keep the load balanced. Place meat on each rack so that the rack remains level (does not tilt forward or rearward). Do not allow meat to extend beyond the rack surface.**

Distribute the entire load so that the rotisserie is relatively balanced. In other words, if you have a pit with six racks, you should distribute about one-sixth of the entire load on each rack. If you are cooking very large items such as turkeys, take special care to insure that they cannot shift and roll off the shelves while cooking. You need to secure these large items to the shelves with butcher's string or wire, or "chock" the items with stainless steel or rolled aluminum foil to prevent movement.

Be sure that there is adequate clearance between the top of the meat items and the top of the cooking compartment. The most serious problem that can occur in your unit is a "rack jam", in which racks become engaged between the rotisserie wheels and the body of the cooking compartment. If a jam should occur, the rotisserie wheels will become locked. There is an overload device in the electrical circuit to protect the motor. This overload device should trip in the event of a jam but damage to racks and other components may have been incurred. A jam usually occurs when the pit is improperly loaded. Sometimes all it takes is for one piece of meat to fall from its rack. This piece can fall onto other pieces causing them to fall. Soon there is an obstruction large enough in the bottom of the pit for a rack to hit it and become dislodged from its pins. If that rack becomes engaged in other racks, or one of the rotisserie wheels, then a rack jam occurs. By carefully loading your pit, you should never have to worry about this problem.

After completing the meat loading, **always** observe at least one full revolution to make sure that all shelves are properly balanced.

After the meat is loaded, set the thermostat to the desired temperature and close the oven doors. Refer to the table on the next page for cooking directions.

SUGGESTED COOKING TIMES AND TEMPERATURES

MEAT ITEM	TEMPERATURE*	COOKING TIME**
Beef Brisket (12 – 14 Lbs.)	200° F.	14 Hours
Pork Shoulder (12 – 14 Lbs.)	200° F.	14 Hours
Pork Ribs (3 and down)	250° F.	3 Hours
Sausage	225° F.	1 Hour
Hams (pre-cooked)	225° F.	2 Hours
Turkeys (whole)	250° F.	45 Min.per Lb.
Chicken Halves	250° F.	2 Hours

*Sensed at the midpoint of the pit.

**These cooking times are based on a full loading in a Models 700E and 1300E Pits (18 racks) and apply to the meat on the bottom racks. With decreased loadings, the cooking times should be reduced. The meat on the top racks will cook in less time.

With the exception of turkeys and ribs, most pit operators do nothing to prepare meats prior to cooking. Usually, a dry seasoning mix (pepper, paprika, brown sugar, etc.) is sprinkled or rubbed onto ribs. Sometimes a liquid mixture of spices is injected beneath the skins of turkeys. Refer to our recipe book for more detailed information.

For Dual Fuel Mode (using electrical heating elements), please refer to pages 1 and 2 of this manual.

GREASE

Grease and water from the meat you cook will accumulate in the bottom of the cooking compartment. This should be drained from the pit daily.

NOTE: Drain all grease and water out of the pit immediately after cooking poultry or seafood.

FIREBOX ASHES

Remove excess ashes daily to provide good air circulation among the logs in the firebox. Leave enough live coals in the firebox to ignite a new fire. Most operators shovel the ashes out of the firebox and into a metal container (such as a J&R Mfg. ash cart and store this container in a safe location (away from combustibles).

MAINTENANCE AND CLEANING

MODEL 700E AND MODEL 1300E

PIT DESIGN

Smoke and heat from the firebox enter the cooking compartment through refractory-lined flues. Smoke exits this area through a separate flue. Temperature control is effected by regulating the flow of combustion air into the firebox and the discharge from the cooking compartment. Dampers in the rear of the pit open in conjunction with the front doors so that smoke is carried out of the building through the smokestack rather than exiting out the oven doors.

MAINTENANCE SCHEDULE

DAILY

- 1) Drain liquid from the pit and discard.
- 2) Remove excess ashes from the firebox and store/discard safely.
- 3) Clean the inside of the front doors and the inside of the firebox door.

WEEKLY It is recommended that once a week you shut your unit down and clean it as follows:

Racks: Remove the racks from the pit and either

- (a) Use detergent and hot water to clean them, or
- (b) Use a high pressure hot water cleaning machine, or
- (c) Use a wire brush to remove the residue, or
- (d) If time permits, place the racks in a vat filled with water and a caustic chemical such as lye (or firebox ashes for economy). The racks will soak clean in approximately 24 hours. You may consider purchasing an extra set of racks so one set can clean while cooking with the other set.
- (e) Always rinse with clean water after using cleaner or lye.

Oven Interior: After draining all the liquid from the pit, you can either

- (a) Use detergent (or buffered oven cleaner) and high pressure water, or
- (b) Use a steam cleaning machine, or
- (c) If high pressure water or a steam cleaning machine is not available, use a high strength buffered oven cleaner and spray it onto the interior oven surfaces. Dilute the cleaner as directed on the label. Use some type of pump sprayer to apply the solution onto the oven interior surfaces. Let the solution set for about 15 minutes and wash the interior walls with water (hot water, if available), or
- (d) Use a scraper and shovel to remove the residue and flush with detergent and hot water, or

- (e) Leave the racks in place and fill the pit with a hot water/oven cleaner solution up to the middle of the exit flue opening. Heat the pit up to 250° and allow the racks to revolve. Continue for at least 4 hours, drain and rinse the pit thoroughly.

Drain the washings from the pit through the drain valve (see Figure 1). If a floor drain is not adjacent to the drain valve, attach a hose or pipe to the valve and extend it over to a suitable drain.

PLEASE NOTE:

Methods (a), (b), and (c) are operable only if pit is cleaned every week. If several weeks pass between cleanings, the cleaner will not penetrate and remove the residue.

PREVENTIVE MAINTENANCE CHECK LIST

EVERY 45 DAYS

BEARINGS Remove the access panel below the front oven doors (or, with newer units, open the lubrication access door on the access panel). The rotisserie bearings have lubrication extensions that terminate with grease fittings located near the motor starter enclosure. Use a high temperature grease (Super Lube Synthetic Grease is recommended) and a cartridge-type automotive grease gun. **NOTE:** Low temperature grease will harden at high temperatures and damage the bearings.

CHAIN Lubricate the chain with the same high temperature grease. Remove the access cover on the drive side adjacent to the front of the unit, or remove the front access panel below the pit doors to access the chain. Check the chain tension and adjust as necessary.

EXIT FLUE CLEANING Clean this flue thoroughly from inside the cooking compartment or remove the rear access cover adjacent to the flue and clean it from the rear of the pit with the flue damper open.

NOTE: If this flue is not kept clean, the solids accumulation can retard the passage of smoke from the oven to the stack, causing soot and/or temperature control problems.

EVERY 6 MONTHS

1. Inspect and repair as needed all gaskets. This includes the front door gaskets, the two bypass gaskets, and the exit flue gasket.
2. Inspect and adjust, repair, or replace the front door latch.
3. Check the temperature control mechanism for proper operation. Cycle the thermostat and make sure the combustion air damper and exit flue damper are opening and closing (tightly). Lubricate all linkages at the rear of the pit. Remove the thermostat faceplate and spray the moving parts with a spray lubricant.

4. Check the evacuation (bypass) system for proper operation. Open the front doors and make sure that the bypass dampers operate properly. They should seal tightly when the front doors are closed and latched (and the “Evac” switch, if the pit is equipped with one, is off).
5. Clean excess carbon build-up or residue from the rear area of the pit, including the inside of the access door above the firebox, the firebox door and the area around the firebox door.

DOOR GASKETS

The oven door gasket should be smoke-tight. To stop smoke leaks, you may need to shim the hinge side, the latch side or both. You may also need to “thicken” the gasketing by using additional RTV silicone between the gasket and the body of the unit. Gaskets can be checked with a “paper test”. Insert a strip of paper so that it is between the door and the gasket and extends outside the pit. Close and latch the door. Pull the paper towards you. It should be very resistant to your effort. If it seems loose, further adjust the door or the gasket thickness.

TROUBLESHOOTING

1). PROBLEM Combustion air damper and exit flue fails to open and close.

CAUSES One of the following components is inoperative:

- (a) the thermostat,
- (b) the damper motor, or
- (c) the linkage between the motor and the dampers.

PROCEDURE

- (a) Open the access door to flues and dampers. (see Figure 1)
- (b) Make sure that the linkage is attached to the motor and that all pivot pins are in place. A simple adjustment may be all that is necessary.
- (c) Inspect the Temperature Control Damper Acuator With a volt meter, check to see if the actuator motor circuit is live by turning the thermostat to its highest setting and check the motor lead-in wires. If 120 volts is present, shut off the pit electrical supply and replace the motor.* If 120 volts is not present, the problem is in the circuitry between the actuator and the Main Control Thermostat. Use the volt meter to trace the control circuit to find the problem, which might include the High Limit Thermostat.

* If the motor is very warm to the touch, it may be that the motor is okay but mal-adjusted so that it is going out on its internal overload. Check for proper adjustment of the linkage before replacing the motor.

2). PROBLEM Adequate cooking temperatures cannot be maintained and / or excessive smoke leakage from the pit.

CAUSES One of the following:

- (a) the combustion air damper and exit flue damper are not opening,
- (b) there is a restriction in the smoke exit system,
- (c) there is excessive heat loss due to the bypass dampers not sealing properly,
- (d) there is insufficient make-up air supply, or
- (e) there is insufficient wood in the firebox.

PROCEDURE

- (a) Proceed as in problem 1, if the combustion damper and exit flue are not opening.
- (b) Verify that the exit flue is clean.
- (b) If the problem still exists, make sure that the two large bypass dampers are sealing against their respective gasketed seats. A problem with these dampers could affect the pit temperature, but it would not explain a smoke leakage problem.
- (d) If none of the above problems is evident, then there is insufficient combustion air for the firebox.

- 3). PROBLEM Excessive smoke emissions from the oven doors when they are open.

CAUSES One of the following:

- (a) rear bypass dampers are not opening,
- (b) negative air pressure in room (usually caused by exhaust fans), or
- (c) insufficient make-up air.

SOLUTION

- (a) Open the access door to the flues and dampers. Inspect the bypass dampers for proper operation. They should both open when the front doors are opened.
- (b) If they do not open when the front doors are opened or when the "Evac" Switch is energized, inspect (and adjust/repair) the linkages at the rear of the pit. The "Evac" damper actuator moves the rear damper linkages to open and close the dampers. It energizes when the front doors open, or when the "Evac" switch is energized. If the dampers do not open after checking the linkages, then troubleshoot the actuator using the same procedure described in Problem 1. If the actuator has no voltage present, then the problem is in the circuitry between the actuator and the switches. Check the wiring, the Rotisserie Switch, the Door Limit Switch and the Evac Switch.

4). PROBLEM Rotisserie does not revolve.

CAUSES One or more of the following:

- (a) motor failure,
- (b) circuit failure,
- (c) gearbox failure,
- (d) broken chain,
- (e) loose sprocket, or
- (f) the overload device has tripped.

PROCEDURE

- (a) Inspect the cooking compartment to be sure that the rotisserie assembly has not jammed. If the assembly is okay and the load is evenly balanced, turn the rotisserie switch to the “off” position and let it sit for about five minutes, then press the blue reset button on the contactor/overload assembly and try the rotisserie switch again. If it still does not revolve, proceed to Step (b).

If there has been a rack jam you will also need to proceed to the next step. Other damage may have been incurred, however, such as damaged racks or rotisserie wheel pins, or rotisserie shaft.

- (b) Make sure that the circuit breaker feeding the pit has not tripped. If it has, reset it and try to operate the rotisserie. If it trips again or if the rotisserie shaft still does not rotate, proceed with the next step.
- (a) Open the motor/gearbox access door. If the gearbox output shaft is rotating but the sprocket is not, then shut the circuit off and tighten the sprocket onto the shaft.

NOTE: Make sure the 1/4 inch square key is in place on the output shaft. If the chain is broken, repair it. If the chain is moving, check the rotisserie shaft sprocket and make sure the key is in place in the keyway.

- (d) If the motor is running but the output shaft on the gearbox is not rotating, proceed to Step (e). If the motor is not running, proceed to Step (f).

Note: the following steps require a skilled technician for safety's sake. There are dangerous moving parts (chain, sprockets, etc.) which can cause serious injury.

- (e) Shut the pit circuit off and remove the motor and gearbox assembly by removing the bolts holding the gearbox onto the base plate. Remove the motor from the gearbox and inspect the coupling between the two. If it is not broken, replace the gearbox.
- (f) If the motor does not run, shut the electrical supply to the pit off and remove the gearbox and motor assembly as indicated above. Separate the two, energize the pit circuit, and turn the rotisserie switch on. If the motor runs, replace the gearbox. If it does not run, replace the motor; however, check the gearbox by rotating the input shaft manually. The output shaft should rotate (remember the output will rotate much slower than the input). If it does not rotate, the gearbox is also defective.

5.) PROBLEM Black residue (carbon) on the meat after cooking or “creosote” odor in smoke.

CAUSES One or more of the following:

- (a) improper wood,
- (b) too much wood in the firebox, or
- (c) improper draft.

PROCEDURE

- (a) Check smoke exit flue and the stack and clean if necessary to remove any obstructions.
- (b) If a new supply of wood is being used, check its type and be sure it is not the problem by using some wood from your regular supply.
- (c) Too much wood in the firebox can cause this problem. Also, if your wood is dry, it can occur. Soot is produced when there is inadequate oxygen available for complete combustion. When you build a roaring fire in the firebox by using too much wood or wood that is too dry, there may be insufficient oxygen available. Reduce the amount of wood you charge into the firebox when this problem occurs.

6.) PROBLEM Rotisserie not revolving smoothly.

CAUSES One or more of the following:

- (a) the chain is loose,
- (b) the gearbox is defective, or one of the sprockets is not secured to its shaft.

PROCEDURE

- (a) Shut the pit circuit off and tag it. Open the motor/gearbox access door. Inspect the chain. It should not have excessive slack over or under the gearbox sprocket. If it does, remove any meat that might be on the racks and loosen the four bolts securing the gearbox to its base. Pull the gearbox toward the front of the pit and re-secure the bolts.
- (b) If the chain was not loose, inspect the gearbox sprocket and rotisserie sprocket to be sure they are secured properly to their respective shafts.
- (c) If they are, then inspect the gearbox as indicated in the section discussing a rotisserie that fails to revolve.

7). PROBLEM Product is cooking too fast or too slow.

CAUSES One or more of the following:

- (a) thermostat is out of calibration, or
- (b) the dampers are not functioning properly.

PROCEDURE

- (a) Check dampers as described in Problems 1 and 2.
- (b) Calibrate as follows:
 - (1) Use a portable hotplate or other device to safely boil water in a pan.
 - (2) Carefully remove the sensing probe from its mounting sleeves and insert it into the pan of rapidly boiling water. The probe must be completely submerged in the boiling water. The probe should not touch the sides of the pan. Adjust the thermostat to match the temperature of boiling water at your elevation.
 - (3) Adjust the thermostat indicating pointer as directed in the thermostat manuals included in this manual.

Oyler Interior Installation with Direct Vent

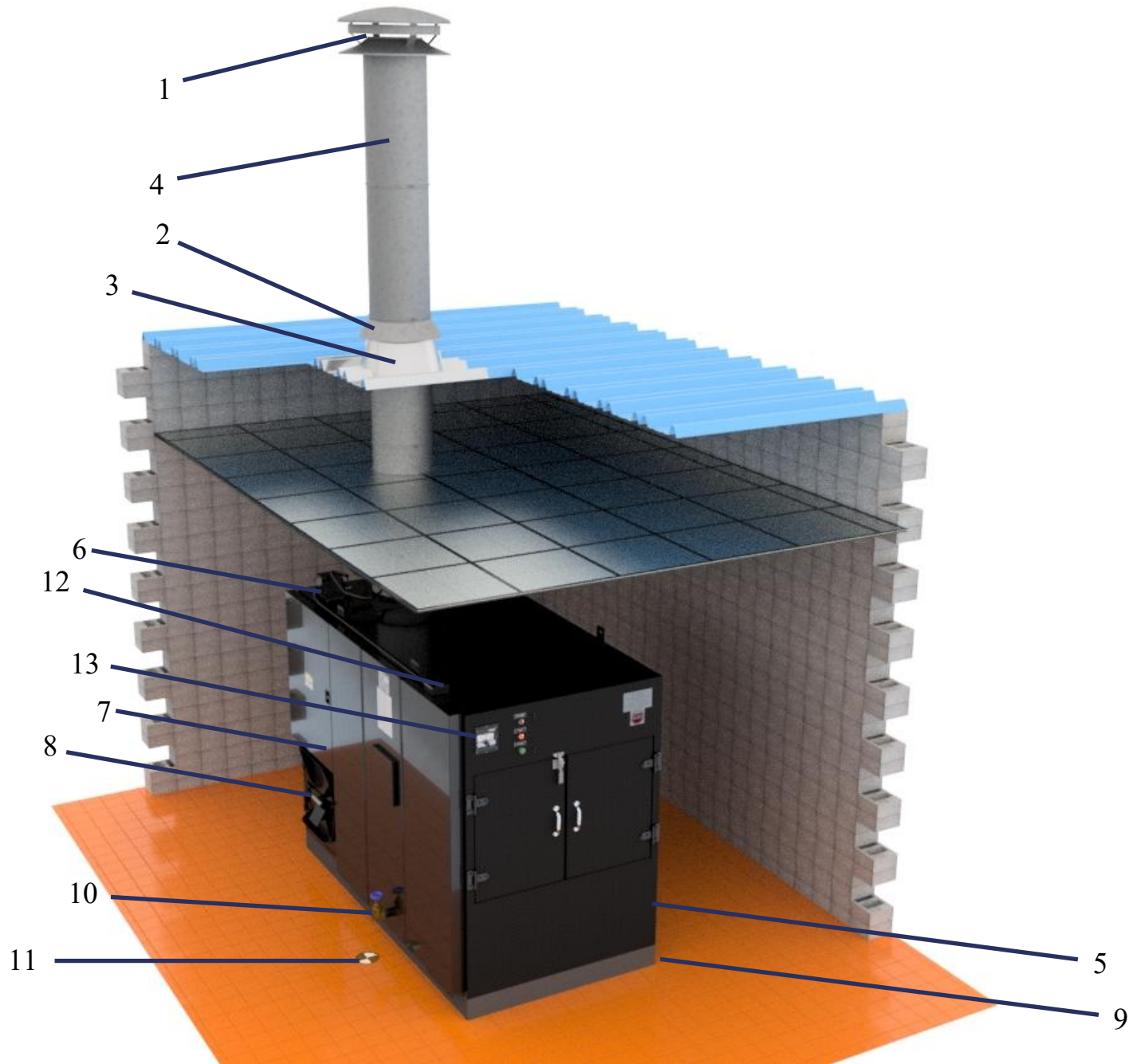
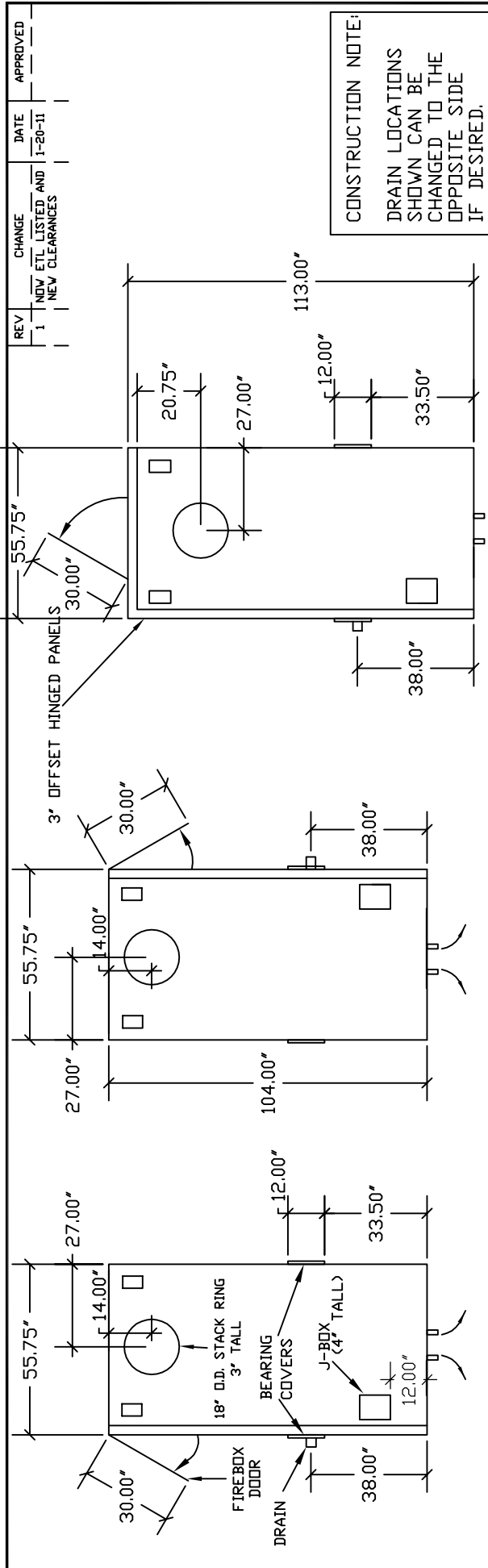

Figure 1

LEGEND

- | | |
|--|---|
| 1. RAIN CAP | 8. FIREBOX DOOR |
| 2. COUNTER FLASHING | 9. CONCRETE PAD (RECOMMENDED)
4 TO 6 INCHES HIGH OR USE STEEL BASE |
| 3. ROOF JACK | 10. DRAIN VALVE |
| 4. SMOKESTACK | 11. FLOOR DRAIN (RECOMMENDED) |
| 5. ACCESS PANEL TO GEARBOX, MOTOR, GREASE FITTINGS | 12. J-BOX FOR ELECTRICAL CONNECTION |
| 6. ACTUATOR MOTORS (6" HIGH) | 13. THERMOSTAT AND CONTROL SWITCHES |
| 7. ACCESS DOORS TO FLUES AND DAMPERS | |



TOP VIEW - LEFT FIREBOX

TOP VIEW - RIGHT FIREBOX

TOP VIEW - REAR FIREBOX

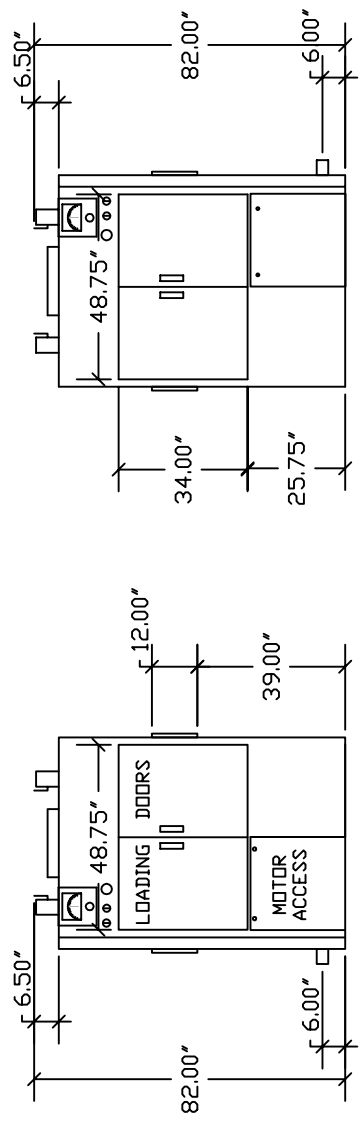

FRONT VIEW - LEFT AND REAR FIREBOX
(4" TALL JUNCTION BOX NOT SHOWN)

FRONT VIEW - RIGHT FIREBOX
(4" TALL JUNCTION BOX NOT SHOWN)

- NOTES:
1. INSTALL ON A NONCOMBUSTIBLE FLOOR. A 4" TO 6" CONCRETE PAD IS RECOMMENDED TO ELEVATE THE GREASE DRAIN.
 2. CLEARANCE FROM COMBUSTIBLES: 12" ABOVE, TOP OF CASING, 48" FROM FRONT, 6" FROM CHIMNEY CONNECTOR, AND 6" FROM SIDES AND BACK. EXCEPT 36" FROM THE FIREBOX DOOR.
 3. CHECK WITH LOCAL CODES FOR VENTING REQUIREMENTS.
 4. ELECTRICAL REQUIREMENTS ARE 240 VOLT, 1 PHASE, 70 AMP. (4 WIRE: L1, L2, N, AND GRD).
 5. ACCESS TO BOTH SIDES, THE REAR, AND FRONT IS REQUIRED FOR SERVICE PURPOSES.
 6. SEE OWNER'S MANUAL FOR ADDITIONAL INFORMATION.

J & R MANUFACTURING		820 V. KEARNEY, MESQUITE, TEXAS 75149	
SCALE	3/8" = 1'	DRAWN BY	L. BELLDOWS
DATE		CHECKED BY	
APPROVED BY		DATE	05-20-02
TITLE			
DETAIL SHEET - MODEL 700E			
PHONES: (972) 285-4855, (800) 327-4831	DRAWING NUMBER	DIS 700E	
FACSIMILE: (972) 288-9488	REVISION NUMBER	1	

ETL LISTED

NSF CERTIFIED

Oyler Through-the-Wall Installation with Direct Vent

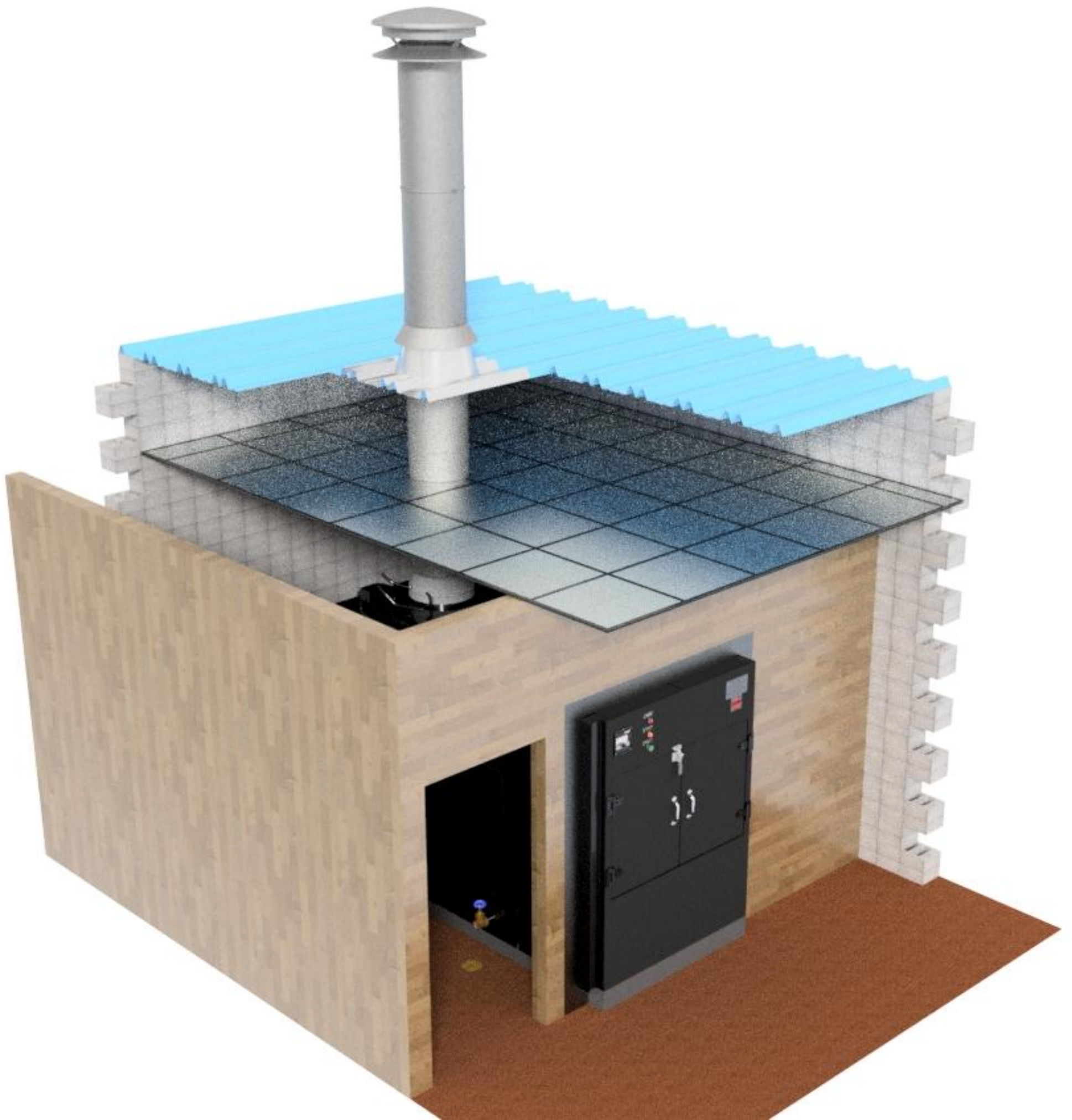
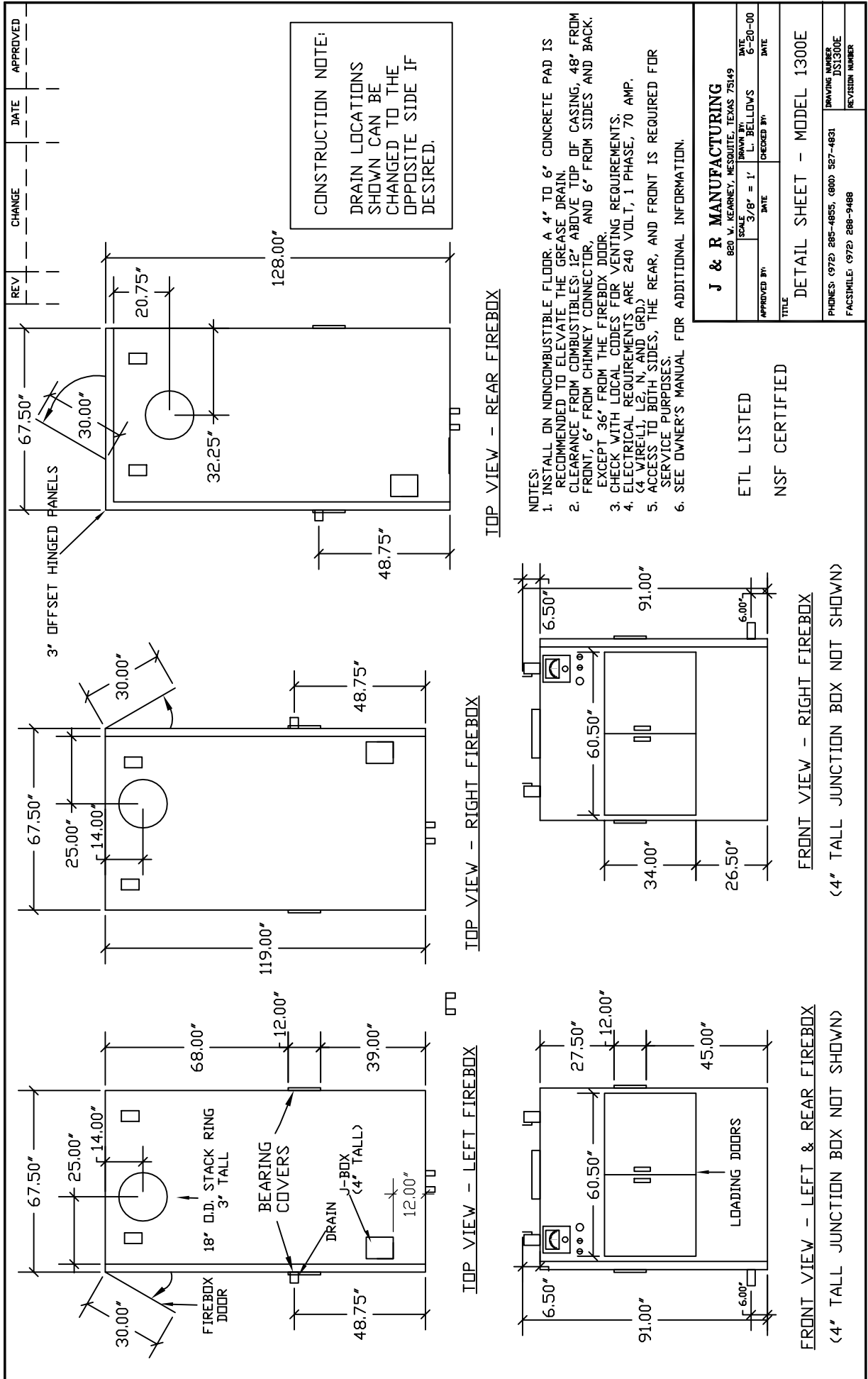

Figure 3



Oyler With Exhaust Hood Vent
Unit shown is a Model 700-Left Firebox



Figure 5

EXHAUST HOOD DESIGN

Always verify with hood and fire suppression vendors and AHJ

Exhaust Hood Design Parameters for Oyler Ovens

1. 12 inch overhang at front of unit.
2. 6 inch overhang, non-active sides and rear (no firebox).
3. 12 inch overhang on firebox side (or rear, for rear firebox units).
4. Filter bank always over chimney connector.
5. Hood elevation: bottom of hood to be a minimum of 2 inches above top of oven(including base if any).

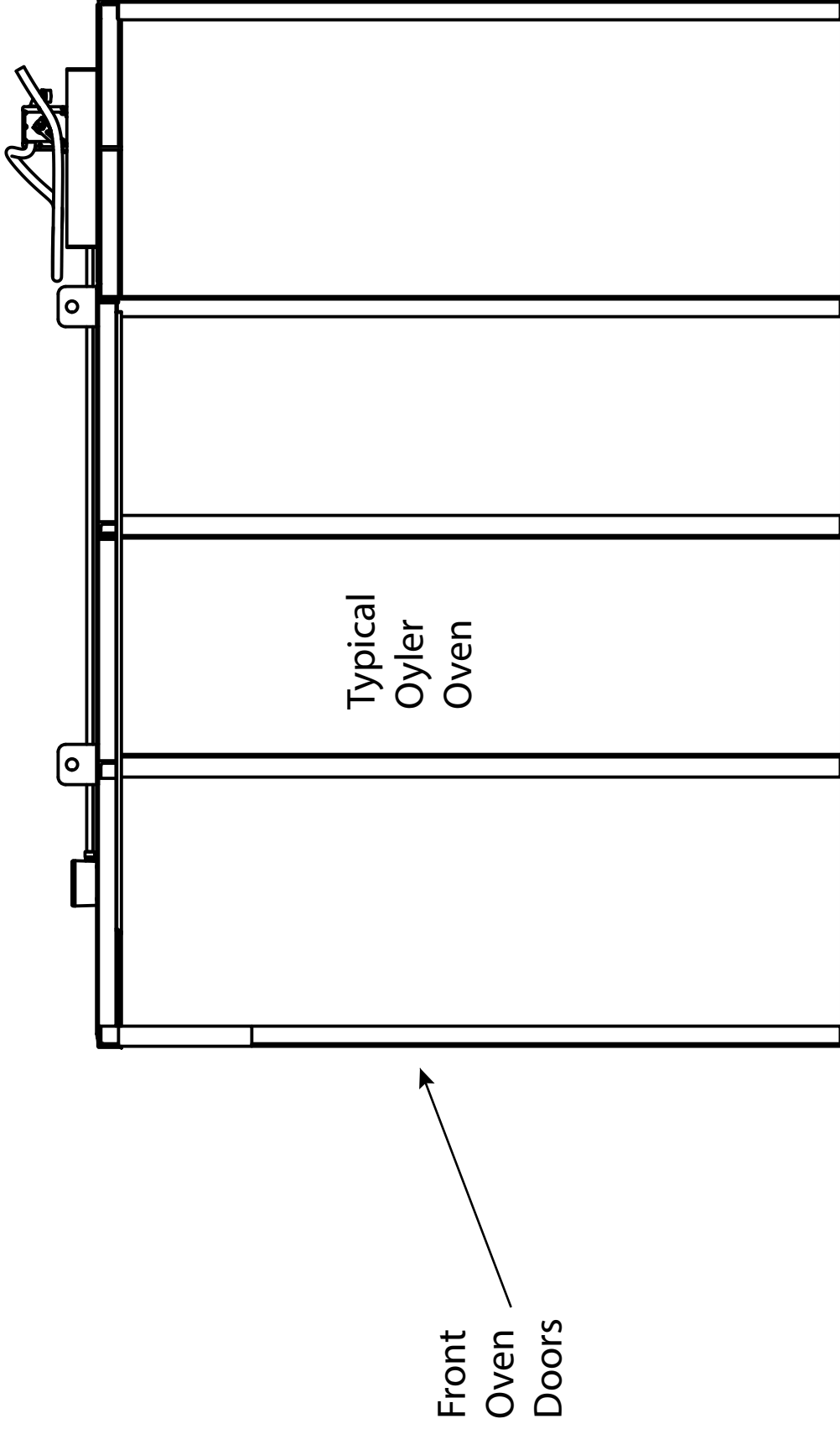
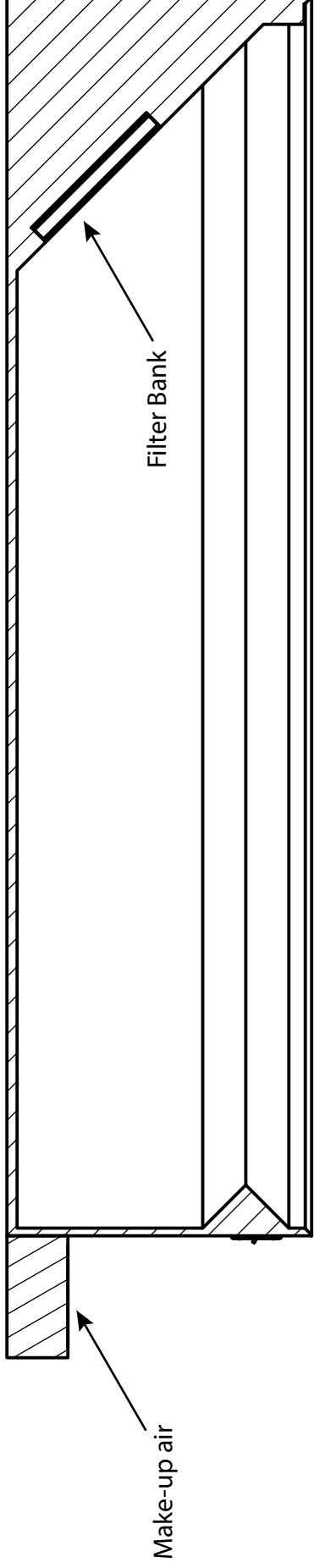

OUR RECOMMENDATIONS

Oyler Model/ Firebox Location	Hood Length (in.)	Hood Width (in.)	Exhaust Volume (cfm)
700 Left or Right	122	73.75	4300
700 Rear	137	67.75	4000
1300 Left or Right	137	85.5	5000
1300 Rear	152	79.5	4700

J&R Manufacturing			
TITLE Oyler Section-Through View - Under Hood			
DRAWN Scott Higgins		DATE 3/28/2017	
SIZE B	DWG NO Oyler Under Hood	REV	
SCALE 1/16			SHEET 1 OF 1

Figure 5A

SMOKESTACK INSTALLATION

(Single wall smokestack-
only for use when no
combustibles are present)

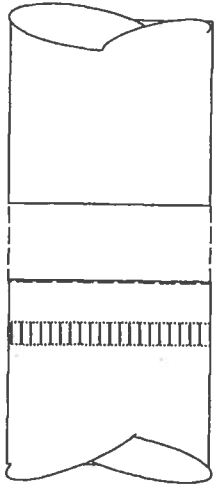

Section A - A

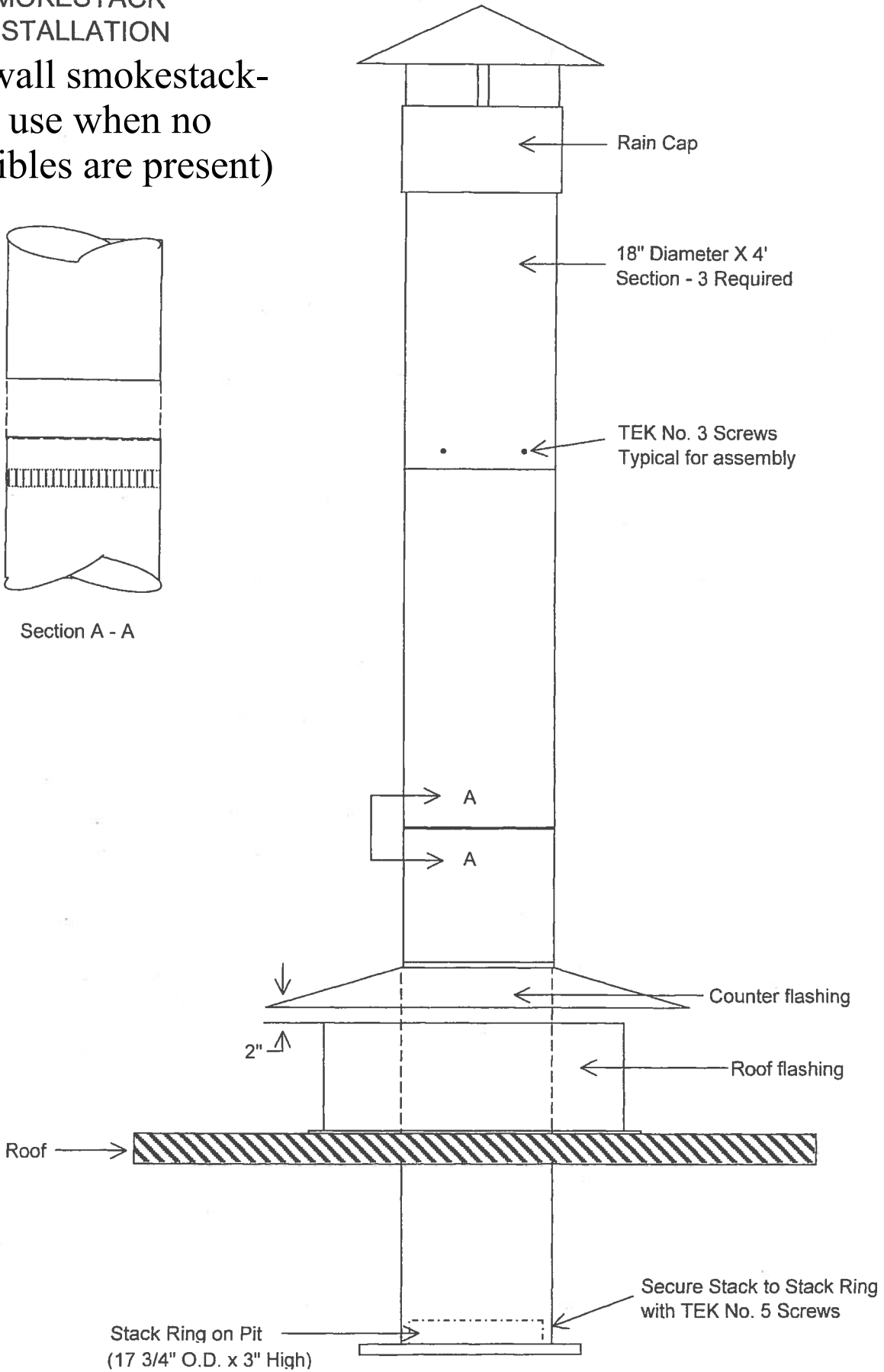

OYLER MODELS 700 & 1300
Cooking Mode

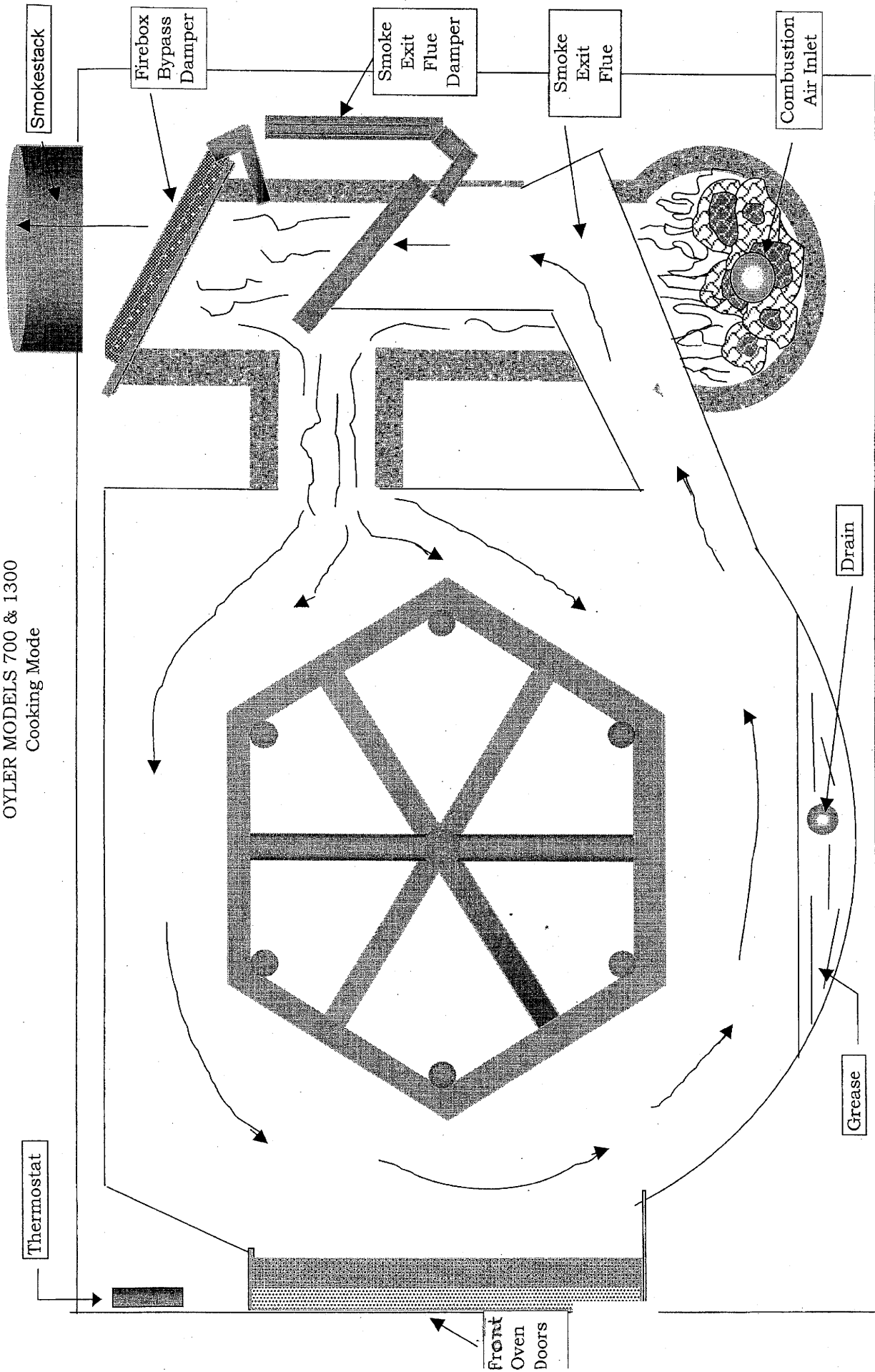

FIGURE 6

Damper Actuators

Oyler Pits utilize two damper actuators, one for temperature control and one for the "Evac" mode. Older units have Barber-Colman actuators and newer units have Schneider Electric actuators. They are identical, other than the name, as Schneider acquired Barber-Colman. Instructions for the actuators are included in this manual (see the Thermostats and Actuator Manuals section). The model for 120 Volt units is MA-418.

These actuators are located on the top rear of the pit near the chimney connector. **IMPORTANT:** When replacing or adjusting the actuator, it is critical that the motor is energized and allowed to reach its full stop position before connecting the linkage rod from the dampers to the ball joint on the "crank arm" (during the power stroke the output shaft travels 180 degrees shaft to reach its stopping point). If the actuator cannot reach this stopping point, it will overheat and fail. With the actuator energized, the crank arm should be installed so that it is in the 11 o'clock position or approximately 150 degrees from the vertically down position (see drawing). After installing the crank arm in the proper position and connecting the linkage rod (with the associated dampers open*) to the ball joint on the crank arm, the device should be cycled (off and on) several times to make sure there is no binding in the linkage components which would shorten the travel of the power stroke. Also, make sure the appropriate dampers fully close when the actuator is de-energized. It is also recommended that this test phase also include the use of an amp meter to determine that the actuator has in fact reached its full travel stop position when energized. The amp reading for 120 Volt units should drop from approximately 0.9 A (running) to 0.3A (stopped or holding).

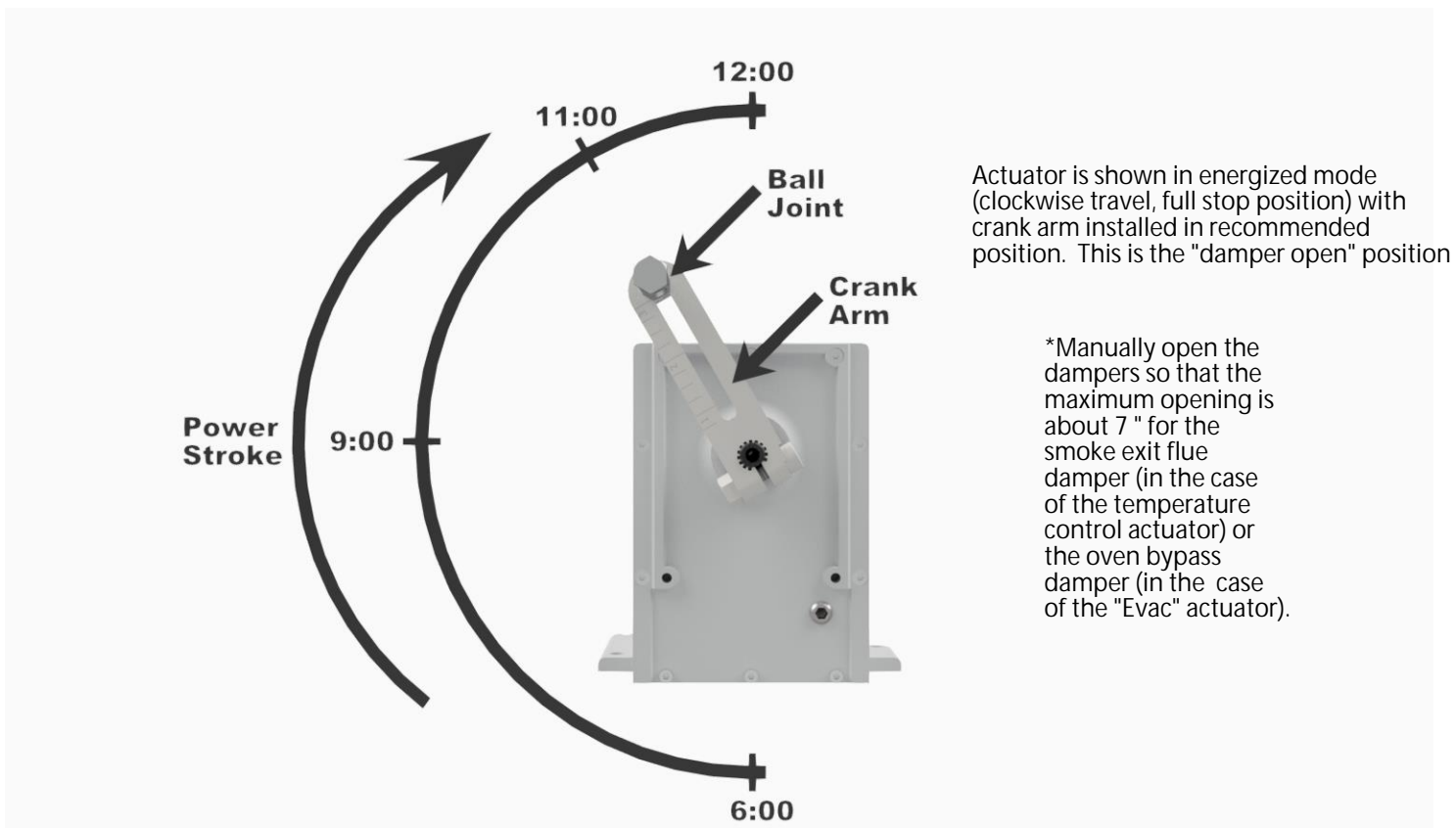
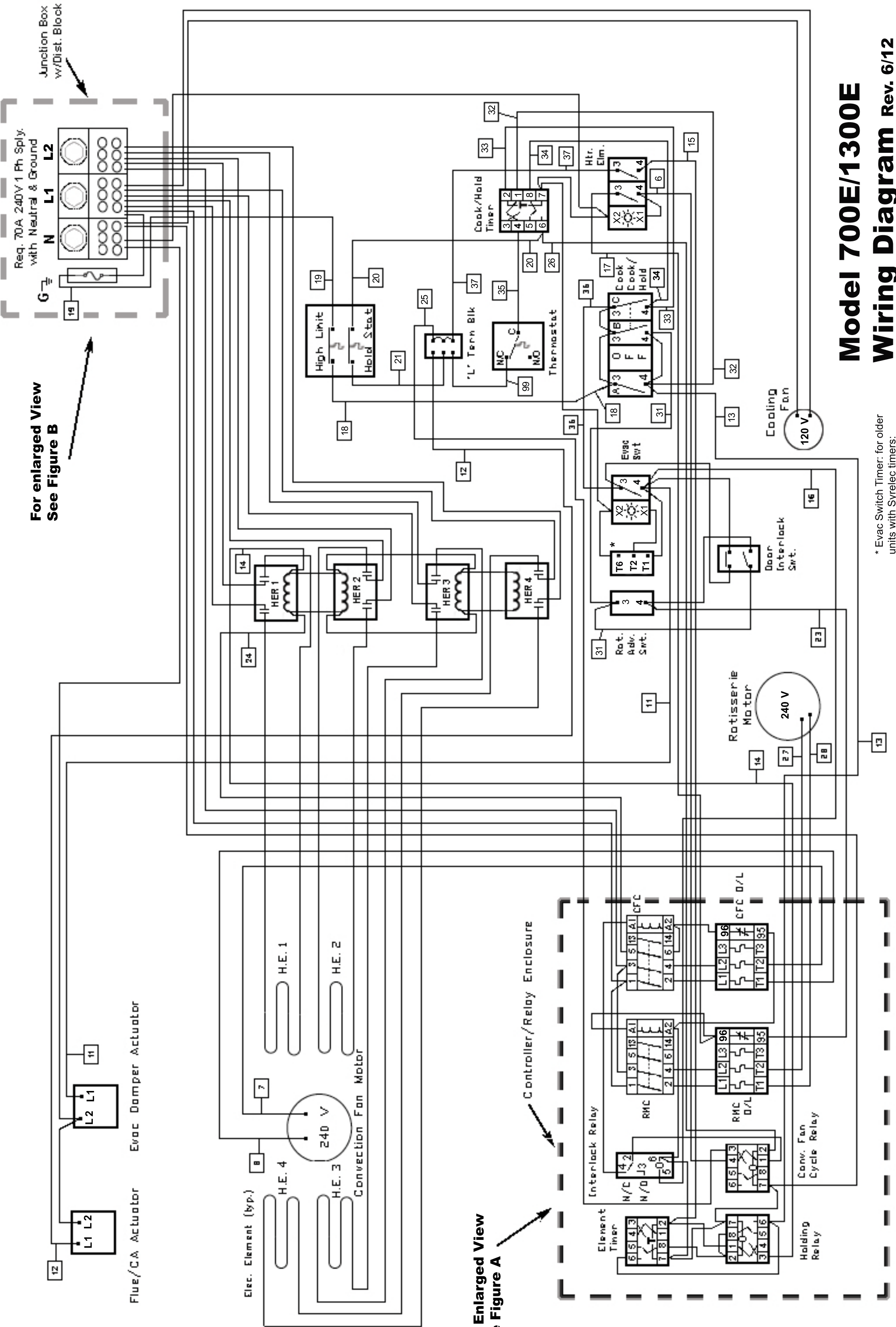

Figure 6A

For enlarged view
See Figure B

For Enlarged View
See Figure A



Model 700E/1300E Wiring Diagram Rev. 6/12

* Evac Switch Timer: for older units with Syrelec timers: T1=A1; T6=A2; T2=1B

Model 700E/1300E Wiring Diagram Figure A

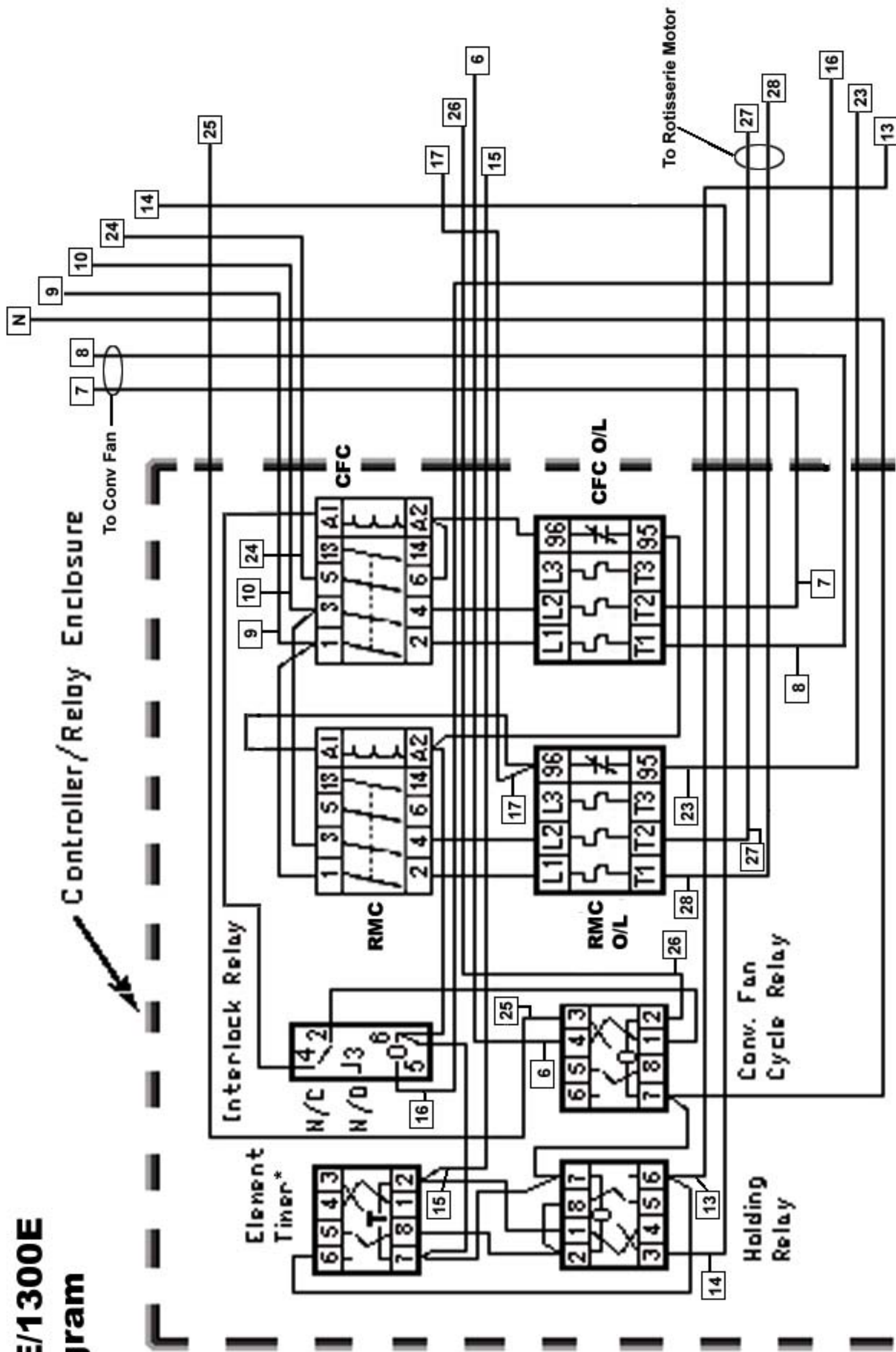

- Legend:**
- RMC Rotisserie Motor Controller
 - RMC O/L Rotisserie Motor Overload (Set to 4 amps)
 - CFC Convection Fan Contactor
 - CFC O/L Convection Fan O/L (Set to 3 amps)
- Note: Set Element Timer to 25 min. using 0-30 min. scale

**Model 700E
and 1300E
Wiring Diagram
Figure B**

Req. 70A 240V 1 Ph Supply
with Neutral and Ground

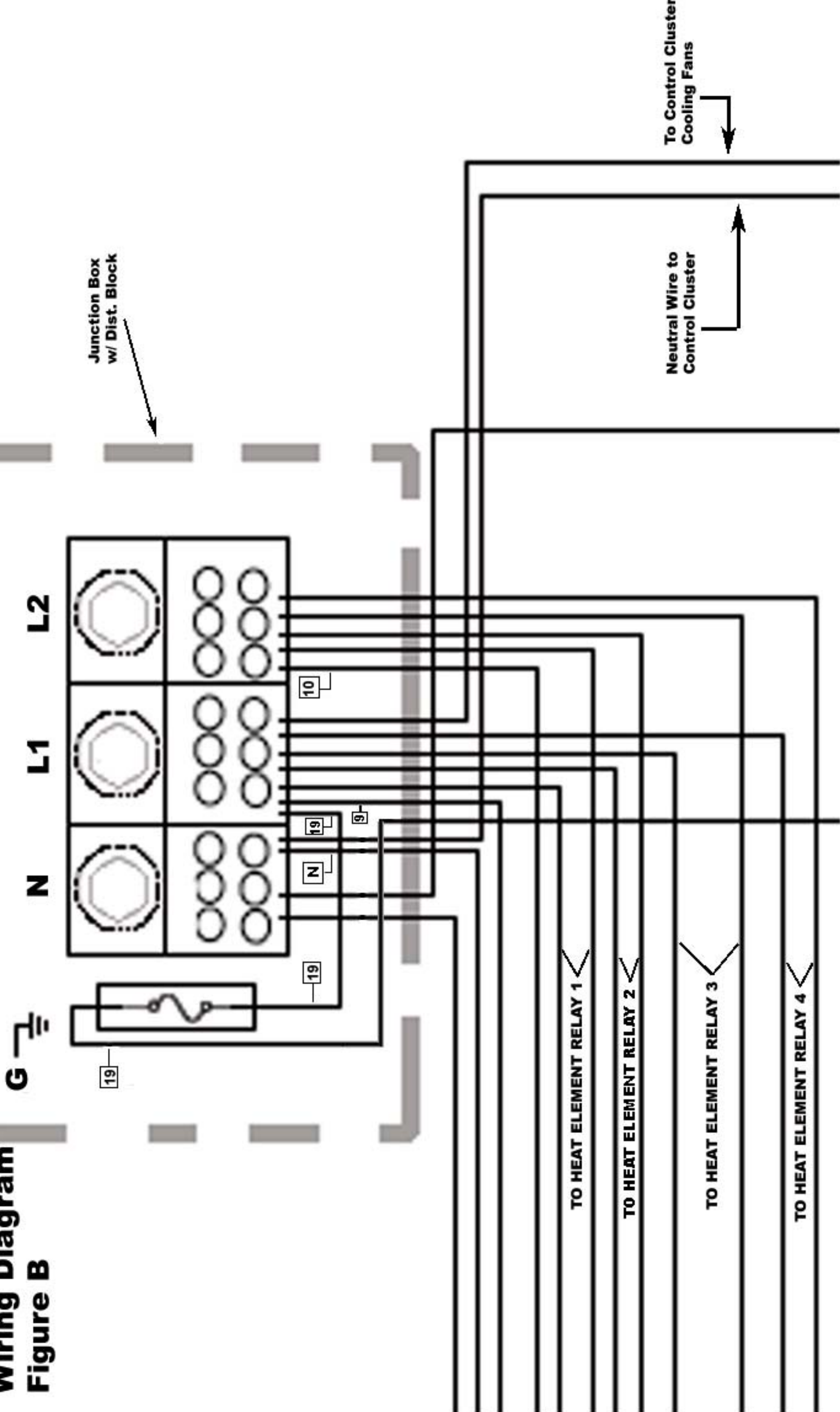



800 Series Indicating Temperature Controls

Types 800, T800, 802

Please refer to IMT120 for Explosion Proof Types 820E and 822E



UNITED ELECTRIC
CONTROLS

Installation and Maintenance Instructions

Please read all instructional literature carefully and thoroughly before starting. Refer to the final page for the listing of Recommended Practices, Liabilities and Warranties.

GENERAL

Temperature variations are sensed by a liquid filled sensing bulb which hydraulically transmits motion through a mechanism which rotates the indicating pointer and actuates precision snap-acting switch(es). Control set point(s) are varied by turning the external adjustment knob(s), according to procedures outlined (See Part II - Adjustments). Thermometer type T800 provides temperature indication only with no snap-acting switch.

MAXIMUM TEMPERATURE: THE HIGHEST TEMPERATURE TO WHICH A SENSING ELEMENT MAY BE OCCASIONALLY OPERATED WITHOUT ADVERSELY AFFECTING SET POINT CALIBRATION AND REPEATABILITY. MAXIMUM TEMPERATURE STATED IN LITERATURE AND ON NAMEPLATE MUST NEVER BE EXCEEDED, EVEN BY SURGES IN THE SYSTEM. OCCASIONAL OPERATION OF UNIT UP TO MAX. TEMPERATURE IS ACCEPTABLE (E.G., START-UP, TESTING). CONTINUOUS OPERATION SHOULD BE RESTRICTED TO THE DESIGNATED ADJUSTABLE RANGE.

Please refer to product bulletins for product specifications. Product bulletins may be found at www.ueonline.com.

Part I - Installation

Tools Needed

Phillips screwdriver to secure customer supplied screws
5/64" Allen Wrench



INSTALL UNIT WHERE SHOCK, VIBRATION AND TEMPERATURE FLUCTUATIONS ARE MINIMAL. DO NOT MOUNT UNIT IN AMBIENT TEMPERATURES EXCEEDING PUBLISHED LIMITS. ORIENT UNIT SO THAT MOISTURE IS PREVENTED FROM ENTERING THE ENCLOSURE.



PREVENTATIVE MAINTENANCE / PERIODIC TESTING (6 MONTHS OR SOONER AS DICTATED BY THE ENVIRONMENT) IS NECESSARY TO ENSURE OPERATION OF THE PRODUCT TO SPECIFICATION. LUBRICATE ALL PIVOT POINTS AND MOVING PARTS, TO PREVENT CORROSION, WITH COMPATIBLE DRY LUBRICANTS OR LIGHT GREASE.

When mounting 800 or 802 type controls, it may be necessary to remove adjustment knob and front cover. The knob is secured with a 5/64" Allen Setscrew. The cover is secured by four phillips screws at the corners.

MOUNTING

The controller may be mounted in any position to either a surface or panel

(1/4" thick maximum). Locate it where vibration, shock and ambient temperature fluctuations are minimal. It is recommended that mounting the unit with the conduit connection on the top be avoided.

To Flush Mount

Cut out the panel as shown in Figure 1A. Mount to the panel using the two holes located on the flange of the enclosure.

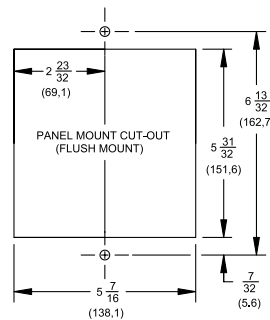

Figure 1A -
Flush Mounting

To Surface Mount

Attach 2 mounting ears found in separate package to recessed areas on back side of enclosure by means of 2 self-tapping screws. Mount to surface per Figure 1B.

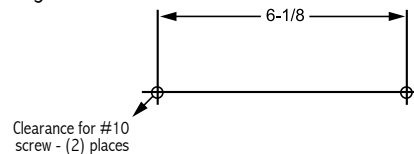

Figure 1B -
Surface Mounting

Mounting Bulb and Capillary

Fully immerse the bulb and 6" of capillary in the control zone. For best control it is generally desirable to place the bulb close to the heating or cooling source in order to sense temperature fluctuations quickly. Be sure to locate the bulb so it will not be exposed to temperature beyond the instruments range limits.

Try to place any remaining capillary adjacent to the control head so it will sense the same ambient temperatures (control is ambient temperature compensated).

Unless otherwise specified, factory calibration, allows for 6" of capillary tube in the control zone. If longer lengths are required recalibration may be necessary. Follow the procedure outlined in PART II - Adjustments.

Avoid bending or coiling the capillary tube tighter than 1/2" radius. Exercise caution when making bends near the capillary ends.

If a separable well or union connector is used follow separate instructions included with them.

WIRING



DISCONNECT ALL SUPPLY CIRCUITS BEFORE WIRING. ELECTRICAL RATINGS STATED IN LITERATURE AND ON NAMEPLATE SHOULD NEVER BE EXCEEDED. OVERLOAD ON A SWITCH CAN CAUSE FAILURE ON THE FIRST CYCLE. WIRE UNITS ACCORDING TO LOCAL AND NATIONAL ELECTRICAL CODES. MAXIMUM RECOMMENDED WIRE SIZE IS 14 AWG.

Types 800, 802

Connect the electrical conduit to the case securing it with the grounding locknut supplied.

Note: Unless control is connected to a metallic conduit, grounding bushing should be removed from grounding wire. A separate conductor should be provided from grounding system directly to the non-current carrying metal parts of control (splice the grounding wire).

Conduit opening is available on the left side as standard. It can be supplied on the right side on request. Wire through the 7/8" conduit hole directly to the lead-wire(s) provided, color coded as follows, or to the optional terminal block.

	Switch 1	Switch 2
Common	Violet	Yellow
Normally Open	Blue	Orange
Normally Closed	Black	Red

See wiring Diagrams Figure 2A and 2B.

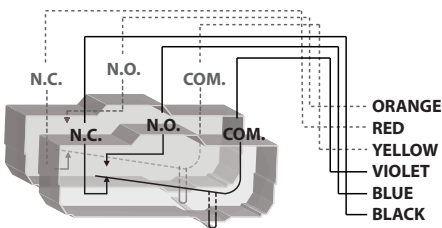

Figure 2A - Dual Switch

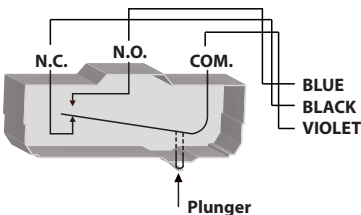

Figure 2B - Single Switch

Optional terminal block wiring is available for single or dual switch controls (option M100). See Figure 2C

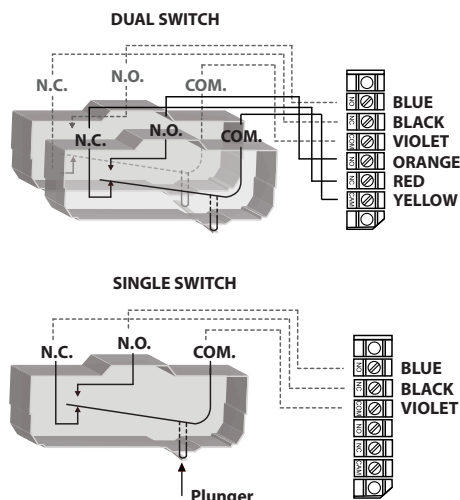

Figure 2C - Terminal Block Option

Part II - Adjustments

(Refer to Figure 3)

Tools Needed

5/64" Allen Wrench
5/16" Open End Wrench (2 required)
Phillips and slotted tip screwdriver

Single Switch Type 800

Move the set point Adjustment Pointer (red) up scale beyond the black Indicating Pointer. This permits checking the set point by moving the lever arm upward with a finger or tool simulating thermal assembly movement. Connect test lights to indicate switch operation or listen for the switch to click. Loosen adjustment "A" and move the Adjustment Pointer until it agrees with the Indicating Pointer. When the switch clicks re-tighten the screw.

Dual Switch Type 802

Type 802 has a separate knob and pointer for each switch. Turn black knob for switch #2 and turn green inserted knob for switch #1. Set points are shown by individual pointers and may be separated up to 100% of dial range apart, so long as the red pointer is set higher than the green pointer.

To align either switch to the Adjustment Pointer the corresponding adjustment "A" must be loosened and the Adjustment Pointer set to the Indicating Pointer, then tighten adjustment "A".

Note: Switch #1, green pointer, cannot be set to operate at a higher setting than switch #2, red pointer.

Connect test lights to indicate switch operation or listen for the individual switch clicks. The separation between switches is the difference between the high and low set points. The set points are determined by setting individual adjustment pointers and may be separated up to 100% of scale range apart.

Replace cover and adjustment knob if removed during installation. Controller is ready for operation. Turn setting pointer to desired control temperature and start up the process. To suit particular process conditions or for greater controller accuracy it may be desirable to make slight alterations to the set point or indicator reading. Procedures for making these adjustments are described below.

In-Process Adjustments

Use an accurate test thermometer such as a thermocouple with its probe mounted directly to the center of the sensing bulb. Before making any adjustments, allow process temperature to stabilize; i.e., successive on-off cycles repeated.

Note: Prior to making any controller adjustments, the cover and adjustment knobs should be removed. The adjustment knob slides off adjustment shaft for all controls except the 802. The 802 requires a 5/64" allen wrench. When adjustments are completed, all applicable parts should be replaced.

Correct any difference between the Indicating Pointer and the test thermometer by holding the compensator with a 5/16" wrench while turning the zero adjustment "C" on the thermal assembly with a second 5/16" wrench, per Figure 3 until the brown Indicating Pointer reads the same as the test thermometer. Turning clockwise lowers indicated reading. Compare the process temperature with the set point Adjustment Pointer. Loosen adjustment screw "A" to align set point Adjustment Pointer with the Indicating Pointer. Re-tighten screw "A".

Adjusting Thermometer Type T800

Use the in-process adjustment to check the control. Differences between the test instrument and the thermometer can be corrected by turning the zero adjustment "C" per Figure 3 on the thermal assembly. Turning in lowers indicated reading.

Note: Indicating Pointer Deflection:

The indicating pointers will read slightly low when the bulb temperature is 15° above the controller setting. This deflection is normal and repeatable (approximately 0.5% of scale range on single switch models) and is due to the transference of the switching mechanism load to the thermal system. It can be measured by moving the setting pointer from the high to the low end of the scale and observing the resultant indicating pointer deflection.

Correction of Capillary

If the length of capillary immersed in the process differs from the amount immersed at the factory calibration bath, a calibration shift will occur. The error may be corrected as follows:

Move set pointer to the highest temperature setting. Note indicating scale reading with the head and sensor at room temperature. Loosen the two thermal assembly mounting screws. Re-position the housing index against the calibration on the instrument case (or skeleton casting) at a rate of 1 division line per capillary length listed in the following column. Move to the left if capillary is to be added to the process, or to the right if capillary is to be removed from process.

Model Number	Range	Cap Length/Division*
1	-180 to 120°F	2 ft
2	-125 to 350°F	1 1/2 ft
3	-125 to 500°F	1 ft
4	-40 to 120°F	4 ft
5	-40 to 180°F	3 ft
6	0 to 250°F	2 1/2 ft
7	0 to 400°F	2 ft
8	50 to 650°F	2 ft

* Added to or taken away from the process.

Tighten the two thermal assembly mounting screws. Note change indicated scale reading (if any).

Turn zero adjustment "C" to bring indicating pointer reading back to the original reading noted before. Turning in lowers indicated reading.

Note: The thermal assembly can be returned to its original position by aligning its flange with the line scribed on the instrument case.

General Layout

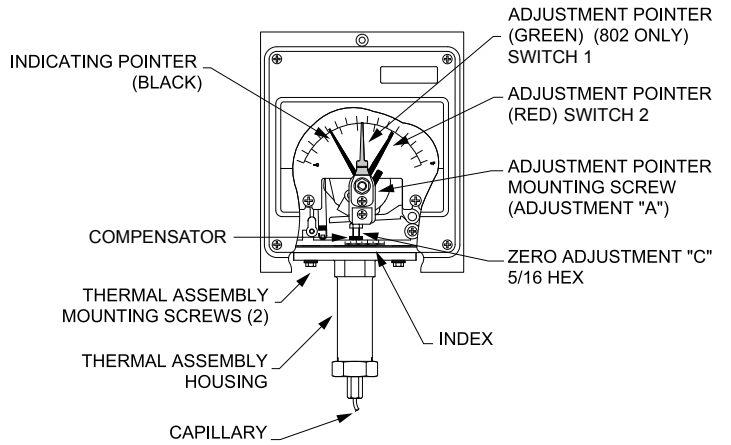

Figure 3

Dimensions

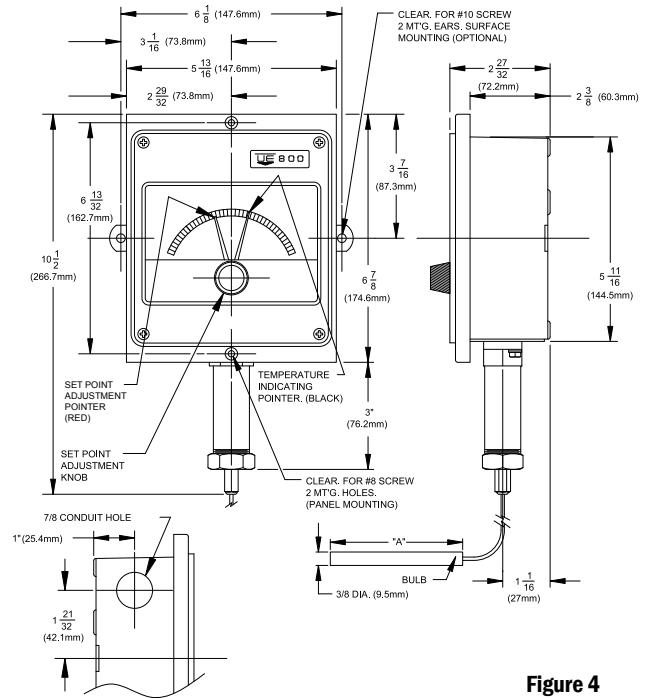

Figure 4

Dimension A

Model	Inches	mm
1BS	3-3/4	95.3
2BS	2-5/8	66.7
3BS	2-1/8	54.0
4BS	6-3/4	171.5
5BS	5	127.0
6BS	4-1/2	114.3
7BS	3	76.2
8BS	3-1/4	82.6

SINGLE SWITCH INDICATING MECHANICAL TEMPERATURE CONTROLLER

This single switch indicating temperature controller operates fuel valves or relays which start and stop heating or cooling systems in a wide variety of applications. It is the smallest and most compact of the indicating mechanical instruments. It derives its simplicity and efficiency from the Piston-Pak filled systems sensing element.



Form Number 3000
Published Jan. 1992
Third Edition

ISO 9002 REGISTERED

**SPECIFICATIONS
INSTALLATION
OPERATION**

OVERVIEW

Partlow

The Partlow Corporation • Two Campion Rd. • New Hartford, NY 13413 USA • 315-797-2222 • FAX 315-797-0403

QUALITY INSTRUMENTATION DESIGNED & MANUFACTURED IN THE USA

MAINTAINING YOUR MF79

CHECKING TEMPERATURE

When checking and verifying your temperature be sure to use a test thermometer of known accuracy. Position the test thermometer sensing bulb or probe adjacent to the thermal sensing bulb from the MF79. Turn the red set pointer on the MF79 to the desired process temperature or above. Wait for the temperature to stabilize, then compare the test thermometer reading with that of the MF79 (Black indicating pointer). If the two readings do not agree, the MF79 should be re-zeroed.

RE-ZEROING YOUR MFS

Be sure that the process temperature is stable. Move the red set pointer to the temperature indicated by the test thermometer. Remove the setting knob on the instrument cover (See exploded view illustration, page 6). Loosen the set screw S (Figure 3, below) and using the 3/16 inch wrench provided with the MF79 turn shaft J until the black indicating pointer reading matches the test thermometer reading. Tighten the set screw S. Check the adjustment by allowing the temperature to stabilize and compare the readings. Repeat these steps if necessary.

Figure 2 - 3 Wire Switch

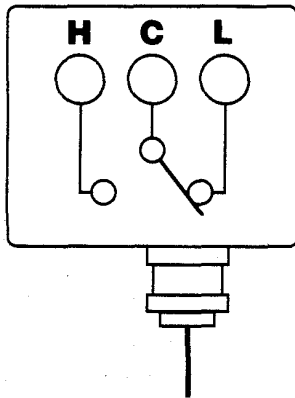

NOTE: Illustration shows switch condition below set point C to H will be continuous above set point.

SWITCH REPLACEMENT & #73 SWITCH INSTALLATION

Turn the power to the MF79 off. Remove the setting knob and cover (See exploded view illustration, page 6) and remove the two screws holding the switch to the switch arm. Take out the existing switch and remove the wires. Re-connect the wires to the replacement switch one wire at a time to avoid confusion. (When installing a #73 switch re-connect the wires to the same respective terminals as on the #79 switch). Then re-assemble the switch in the mechanism, replace the MF79 front cover and knob. Then turn on the power. **Note: After replacing the switch it may be necessary to make an adjustment to the switch actuation screw E (Figure 4, below). If, during normal process temperature cycling, the black indicating pointer registers a constant differential over or under the red set pointer adjust the actuation screw E to correct. Lengthening the screw lowers the temperature while shortening it raises the temperature.**

BRAKE TIGHTENING

Periodically the setting shaft brake may require tightening. If the brake is too loose, the overtravel movement of the black indicating pointer will tend to drag the red set pointer upscale from its set position. To tighten the brake, turn the adjustment screw U clockwise (Figure 5, below). **Do not over-tighten.**

Figure 3 - Re-Zeroing

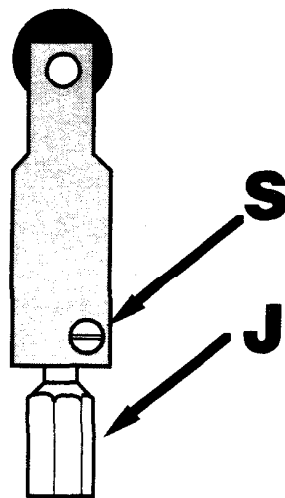

Figure 4 Switch Replacement

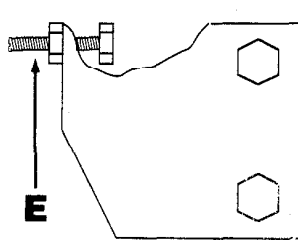
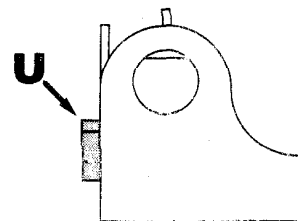

Figure 5 - Brake Tightening



Exploded Illustration and Parts List

1. Cover Assembly
Includes: Cover, Cover Glass, Cover Screws

64415801

2. Knob Assembly
Includes: Knob, Set Screw

64410401

3. Mechanism Assembly
Includes: Micro Switch (#79), Wiring and Terminal Block, Push Rod.

10074014

4. Main Lever Assembly
Includes: Main Lever with Push Rod Cap, Push Rod, Set Screw.

64415901

5. Micro Switch Kit
Includes Terminal Screws
#73
#79

64403018
64403021

6. Case
Includes: Case, Top Plate, Terminal Block Mounting Brackets and Screws, Mounting Brackets with Screws.

64416001

7. Mounting Brackets

64402002

8. Fastener Kit (Not Shown)
Includes:
Cover Screws (2)
Switch Screws (2)
Dial Screws (2)
Terminal Block Screws (2)
Mechanism Holding Screw (1)
Mounting Bracket Screws (2)
Push Rod Set Screw (1)
Top Plate Screws (2)

64416101

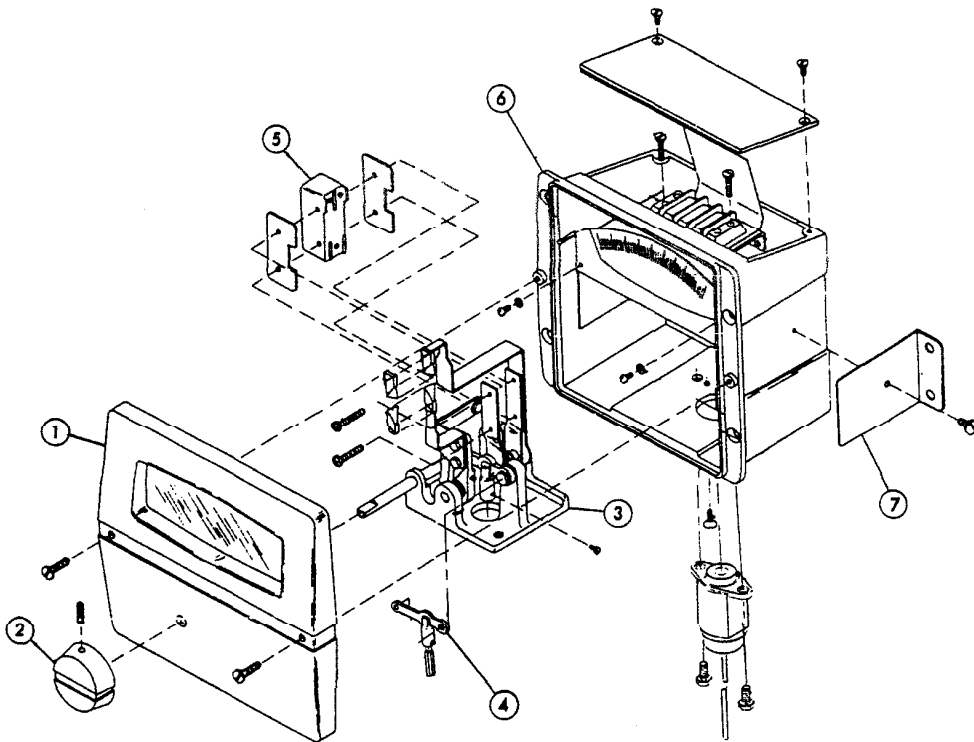

Application

For two-position operation of dampers, valves, and other equipment which require the return to normal position upon power interruption.

Hazardous location models offer a sturdy cast aluminum case with bolted cover. They have two 3/4" pipe tapped openings for joints with rigid metal conduit. All wiring is brought out to separate terminals for ease of installation. These factory enclosure and actuator assemblies are Underwriters Laboratories listed.

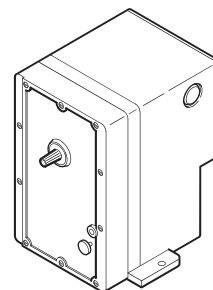

MA-3xx, MA5-318,
MA-4xx, MA5-419
(Standard)

Features

- Compatible with most SPST control devices
- Spring return
- 24, 120, 208, and 240 Vac models
- Actuators with part number suffix "-500" are equipped with SPDT auxiliary switch
- Actuator has a rugged die cast aluminum housing with two 1/2" conduit openings
- Hazardous location actuator housing has two 3/4" pipe taped openings for rigid metal conduit connection
- Oil immersed motor and gear train

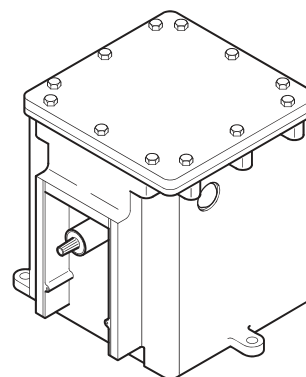

MA6-3xx, MA6-4xx, MA7-4xx,
MA8-3xx, MA8-4xx
(Hazardous Locations)

Applicable Literature

- *Electric/Electronic Products Catalog*, F-27382
- *Valve Products Catalog*, F-27384
- *Cross-Reference Guide*, F-26789
- *AV-29x Valve Linkage for Hazardous Location Gear Train Actuators General Instructions*, F-27441.
- *Apparatus for Hazardous Locations EN-56-2*, F-18451.
- *AV-390 Series, Valve Linkage for Gear Train Actuators General Instructions*, F-24376.
- *Material Safety Data Sheet (MSDS) for BCS-51-168 Oil (Until Feb. 1989)*
- *Material Safety Data Sheet (MSDS) for BCS-51-185 Oil (Until March 2002) (MAX-3xx-x-x-3 and MAX-4xx-x-x-3)*
- *Material Safety Data Sheet (MSDS) for BCS-51-185-1 Oil (Current) (MAX-3xx-x-x-4 and MAX-4xx-x-x-4)*
- *High Temperature Exposure Performance (UL 555S) MAX-31x-x-x-4, MAX-41x-x-x-4 Series Actuators Engineering Information EN-216*, F-27068

SPECIFICATIONS

Actuator Inputs

Connections: Coded screw terminals.

Control Circuit: Two-wire.

Power Input: See Table-1.

Actuator Outputs

Torque: See Table-1.

Shaft Rotation:

MA-305, MA-405, MA6-305, MA6-405, CW 180° when power is applied.

MA-318, MA-41x, MAx-318, MAx-41x, CW 180° when power is applied.

Spring Return: CCW to the original position when the actuator is de-energized.

Auxiliary Switch (-500 Models): SPDT makes (or breaks) the circuit at the powered end of stroke.

Environment

Ambient Temperature Limits:

Shipping & Storage, -40 to 136 °F (-40 to 58 °C).

Operating, -40 to 136 °F (-40 to 58 °C).

Humidity: 5 to 95% RH, non-condensing.

Location: NEMA Type 4 when used with the gasket (provided) and water-tight conduit connectors (not provided), optional hazardous location models.

Agency Listings:

US Standard UL 873, Underwriters Laboratories (File #E9429 XAPX, Temperature Indicating and Regulating Equipment).

Canadian Standard C22.2 No. 24: Underwriters Laboratories (File #E429 Category XAPX7, Temperature Indicating and Regulating Equipment).

Hazardous Location Models, UL file #E29291. Designed for use in hazardous locations N.E.C., Class 1, Groups C and D, and Class 2, Groups E, F, and G. Temperature code T6 for hazardous housing.

Table-1 Model Chart.

Part Number	Power Supply		Auxiliary Switch ^a	Input Watts	VA		Rated Torque lb-in. (N-m)	No Load Timing in Seconds at 75 °F (24 °C) ^b	Mounting	Application
	Vac	Hz			Running	Holding				
MA-305	24	60	No	25	56	56	16 (1.8)	20	Any Position (Horizontal Output Shaft Position Preferred)	Damper Actuators
MA-305-500			Yes							
MA-405	120		No		48	48				
MA-405-500			Yes							
MA-318	24	No	70 Running	92	32	60 (6.8)	20	Output Shaft Must Be Horizontal	Damper and Valve Actuators	
MA-318-500		Yes								
MA-416	208	No		104	38					
MA-416-500		Yes								
MA-418	120	No	25 Holding	108	42	60 (6.8)	20	Output Shaft Must Be Horizontal	Damper and Valve Actuators	
MA-418-500		Yes								
MA-419	240	No	50	120	39	60 (6.8)	20	Output Shaft Must Be Horizontal	Damper and Valve Actuators	
MA-419-500		Yes								
MA5-419		No								
MA5-419-500	Yes									

a 4.4 FLA, 26.4 LRA @ 24 or 120 Vac; 2.4 FLA, 13.2 LRA @ 240 Vac.

b Spring return timing with full load opposing spring is approximately 60 sec.

TYPICAL APPLICATIONS (Wiring Diagrams)

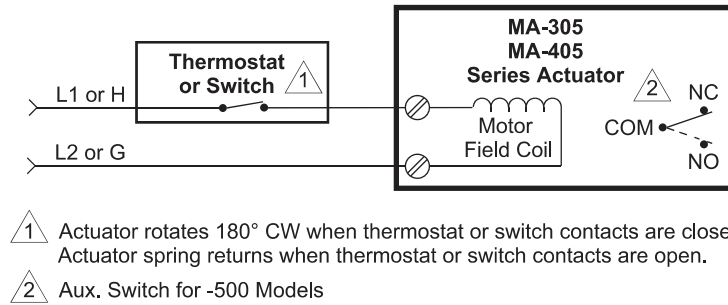

Figure-1 Typical Wiring for MA-305 and MA-405 Series.

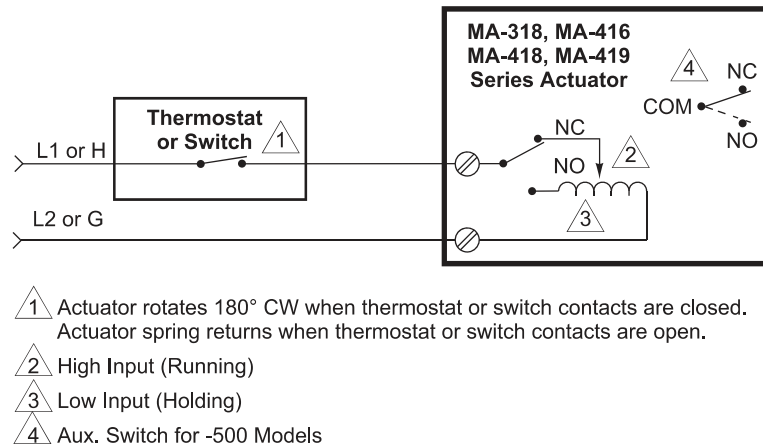

Figure-2 Typical Wiring for MA-318, MA-416, MA-418, and MA-419 Series.

Table-3 Power Wire Selection.

Actuator Series	Wire Size AWG	Maximum Run ^{a b} ft (m)
MA-305	14	122 (37)
	12	191 (58)
	10	305 (93)
MA-405	14	2800 (853)
MA-318	14	44 (13)
	12	68 (21)
	10	110 (34)
MA-416, MA-418, MA-419	14	950 (290)
	12	1580 (482)

a Each run has two wires.

b The length given is for a maximum two-wire run, for one actuator. When multiple actuators are used, determine the maximum run for each actuator by dividing the number of actuators into the corresponding maximum run.

CHECKOUT

After the entire system has been installed and the actuator has been powered up, perform the following check for proper system operation. Check for the correct operation of the damper while the actuator is being stroked.

Note: Smoke control systems must be tested in accordance with NFPA Standard 92A.

1. Verify that the system wiring is properly connected and powered.
2. Be sure the controller (manual or automatic) is operating properly according to system requirements.
3. When the controller energizes the actuator, the output shaft must run to the end of the stroke (180° CW).
4. When the controller de-energizes the actuator, the spring will return the output shaft to its original position.
5. The action of the auxiliary switch (-500 models only) shall be as follows:
 - a. C makes to N.C. when the actuator is de-energized. Refer to (Figure-8).
 - b. C makes to N.O. when the actuator is energized and the output shaft reaches the end of the stroke.

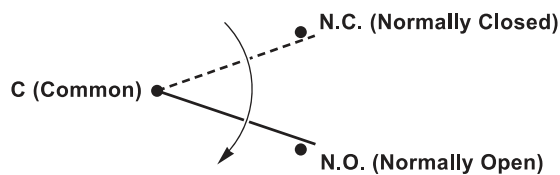

N.O. makes when actuator is energized and output shaft reaches end of stroke.

Figure-8 Action of Auxiliary Switch (-500 Models Only).

THEORY OF OPERATION

MA-305 and MA-405 series actuator output shafts rotate 180° clockwise when energized and spring return counterclockwise to 0° when de-energized.

MA-31x and MA-41x series actuator output shafts rotate 170° clockwise when energized and spring return counterclockwise when de-energized.

MA-305 and MA-405 series actuator motors are assembled to a gear train and stall at the end of the power stroke.

MA-318, MA-416, MA-418, and MA-419 series actuators have an end of travel switch which reduces the running input from 70 watts to 25 watts at the end of clockwise shaft rotation.



RTE-P1, -P2, -B1, -B2 ALL MULTI-TIMERS INSTRUCTION SHEET

Read this instruction sheet to make sure of correct operation before starting installation, operation, maintenance, and inspection of the RTE series timers. The end user should keep this instruction sheet for future reference.

TIME RANGE Determined by Time Range Selector and Dial Selector (hr: hours)

Dial Range	0-1	0-3	0-10	0-30	0-60
s	0.1sec - 1sec	0.1sec - 3sec	0.2sec - 10sec	0.6sec - 30sec	1.2sec - 60sec
min	1.2sec - 1min	3.6sec - 30min	12sec - 10min	36sec - 30min	1.2min - 60min
h	1.2min - 1hr	3.6min - 3hr	12min - 10hr	36min - 30hr	1.2hr - 60hr
10h	12min - 10hr	36min - 30hr	2hr - 100hr	6hr - 300hr	12hr - 600hr

GENERAL SPECIFICATIONS

Operation System	Solid-state CMOS circuit		
Operation Type	Multi-Mode		
Time Range	0.1sec to 600hours		
Pollution Degree	2 (IE60664-1)		
Over voltage category	III (IE60664-1)		
Rated Operational Voltage	AF20	100-240V AC(50/60Hz)	
	AD24	24V AC(50/60Hz)/24V DC	
	D12	12V DC	
	Voltage Tolerance	AF20	85-264V AC(50/60Hz)
	AD24	20.4-26.4V AC(50/60Hz)/21.6-26.4V DC	
	D12	10.8-13.2V DC	
Input off Voltage	Rated Voltage × 10% minimum		
Ambient Operating Temperature	-20 to +65°C (without freezing)		
Ambient Storage and Transport Temperature	-30 to +75°C (without freezing)		
Relative Humidity	35 to 85%RH (without condensation)		
Atmospheric Pressure	80kPa to 110kPa (Operating) 70kPa to 110kPa (Transport)		
Reset Time	100msec maximum		
Repeat Error	±0.2%, ±20msec*		
Voltage Error	±0.2%, ±20msec*		
Temperature Error	±0.5%, ±20msec*		
Setting Error	±10% maximum		
Insulation Resistance	100MΩ minimum (500V DC)		
Dielectric Strength	Between power and output terminals: 2000V AC, 1 minute Between contacts of different poles: 2000V AC, 1 minute Between contacts of the same pole: 1000V AC, 1 minute		
Vibration Resistance	10 to 55Hz amplitude 0.5mm 2 hours in each of 3 axes		
Shock Resistance	Operating extremes: 98m/sec ² (10G) Damage limits: 490m/sec ² (50G) 3 times in each of 3 axes		
Degree of Protection	IP40 (enclosure), IP20 (socket) (IEC60529)		
Power Consumption (Approx.)	TYPE	RTE-P1, -B1	RTE-P2, -B2
	AF20	120V AC/60Hz 6.5VA	6.6VA
		240V AC/60Hz 11.6VA	12.1VA
	AD24(AC/DC)	3.4VA/1.7W	3.5VA/1.7W
	D12	1.6W	1.6W
Mounting Position	Free		
Dimensions	RTE-P1, P2	40H × 36W × 77.9D mm	
	RTE-B1, B2	40H × 36W × 74.9D mm	
Weight (Approx.)	RTE-P1	RTE-P2	RTE-B1, -B2
	87g	89g	85g

* For the value of the error against a preset time, whichever the largest applies.

APPLICABLE STANDARDS

UL508, CSA C22.2 No.14, IEC61812-1, EN61812-1
EMC

Electrostatic Discharge	level 3 Contact ±6.0kV, Air ±8.0kV	IEC61000-4-2 EN61000-4-2
Electromagnetic Field	level 3 10V/m, AM 80%, 80M-1000MHz	IEC61000-4-3 EN61000-4-3
Fast Transient/Burst	level 3 Power Supply: ±2.0kV	IEC61000-4-4 EN61000-4-4
Surge	AF20	level 3 Power Supply: Line to Line ±1.0kV Line to Ground ±2.0kV
	AD24 D12	level 2 Power Supply: Line to Line ±0.5kV Line to Ground ±1.0kV
Radiated Emission	Group 1 Class A	CISPR 11 EN55011

TYPES

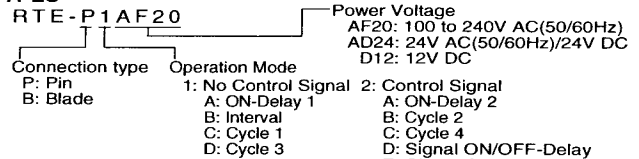

CONTACT RATINGS

Contact Configuration	2 Form C, DPDT (Delay output)	
Allowable Voltage / Allowable Current	240V AC, 30V DC / 10A	
Maximum Permissible Operating Frequency	1800 cycles per hour	
Rated Load	Resistive	10A 240V AC, 30V DC
	Inductive	7A 240V AC, 30V DC
	Horse Power Rating	1/6 HP 120V AC, 1/3 HP 240V AC
Conditional Short Circuit	Fuse 10A, 240V	
Life	Electrical	500,000 op. minimum (Resistive)
	Mechanical	50,000,000 op. minimum

TEMPERATURE DERATING CURVES

Mounting A

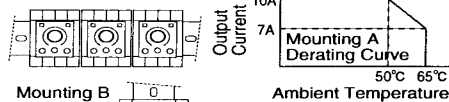

Mounting B

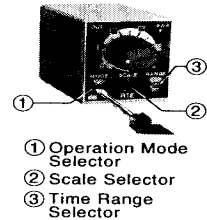
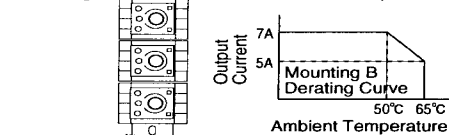

SWITCH SETTING

- Turn the selectors securely using a flat screwdriver 4mm wide maximum. Note that incomplete setting may cause malfunction. Do not turn the selectors beyond the limits.
- Since changing the setting during timer operation may cause malfunction, turn power off before changing the setting.

DIMENSIONS

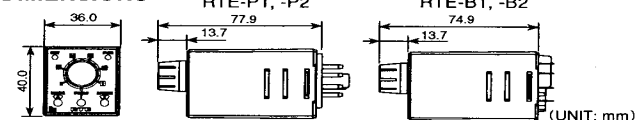

Safety Precautions

- Special expertise is required to use the Electronic Timer.
- All Electronic Timers are manufactured under IDEC's rigorous quality control system, but users must add a backup or fail safe provision to the control system using the Electronic Timer in applications where heavy damage or personal injury may be caused in case the Electronic Timer should fail.
 - Install the Electronic Timer according to instructions described in this instruction sheet and the catalog.
 - Make sure that the operating conditions are as described in the catalog. If you are uncertain about the specifications, contact IDEC in advance.
 - In this instruction sheet, safety precautions are categorized in order of importance to Warning and Caution.
- Warning** Warning notices are used to emphasize that improper operation may cause severe personal injury or death.
- Turn power off to the Electronic timer before starting installation, removal, wiring, maintenance, and inspection on the Electronic Timer. Failure to turn power off may cause electrical shocks or fire hazard.
 - Do not use the Electronic Timer for an emergency stop circuit or interlocking circuit. If the Electronic Timer should fail, a machine disorder, breakdown, or accident may occur.

Caution

- Caution notices are used where inattention might cause personal injury or damage to equipment.
- The Electronic Timer is designed for installation in equipment. Do not install the Electronic Timer outside equipment.
 - Install the Electronic Timer in environments described in this instruction sheet and the catalog. If the Electronic Timer is used in places where the Electronic Timer is subjected to high-temperature, high-humidity, condensation, corrosive gases, excessive vibrations, and excessive shocks, then electrical shocks, fire hazard, or malfunction will result.
 - Use an IEC60127-approved fuse and circuit breaker on the power and output line outside the Electronic Timer.
 - Do not disassemble, repair, or modify the Electronic Timer.
 - When disposing of the Electronic Timer, do so as an industrial waste.

IDEC IZUMI CORPORATION <http://www.idec.com>
Instruction Sheet B-766-0 June 2003

OPERATION CHART

RTE-P1, -B1

A: ON-Delay 1 (power start)

Set timer for desired delay, apply power to coil. Contacts transfer after preset time has elapsed, and remain in transferred position until timer is reset. Reset occurs with removal of power.

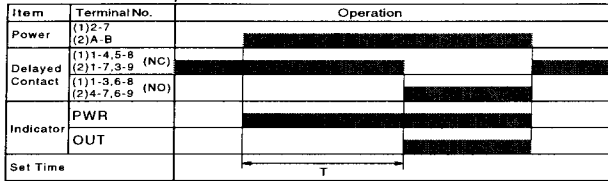

B: Interval (power start)

Set timer for desired delay, apply power to coil. Contacts transfer immediately, and return to original position after preset time has elapsed. Reset occurs with removal of power.

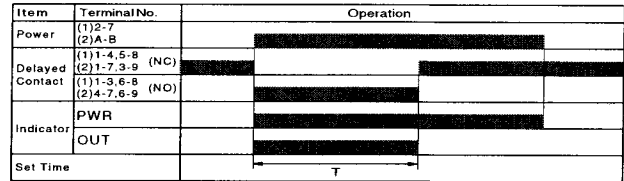

C: Cycle 1 (power start, OFF first)

Set timer for desired delay, apply power to coil. First transfer of contacts occurs after preset delay has elapsed, after the next elapse of preset delay contacts return to original position. The timer now cycles between on and off as long as power is applied (duty ratio 1:1).

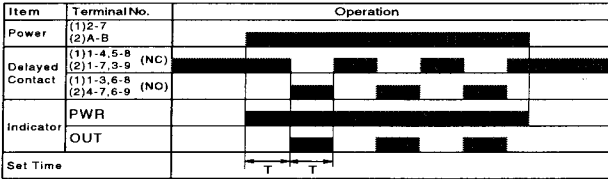

D: Cycle 3 (power start, ON first)

Functions in same manner as Mode C, with the exception that first transfer of contacts occurs as soon as power is applied. The ratio is 1:1. Time On = Time Off

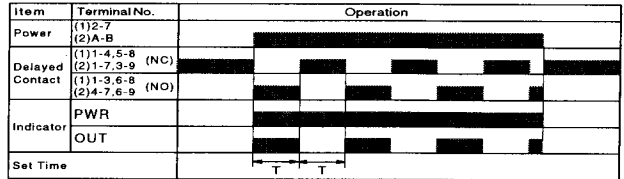

RTE-P2, -B2

A: ON-Delay 2 (signal start)

When a preset time has elapsed after the start input turned on while power is on, the NO output contact goes on.

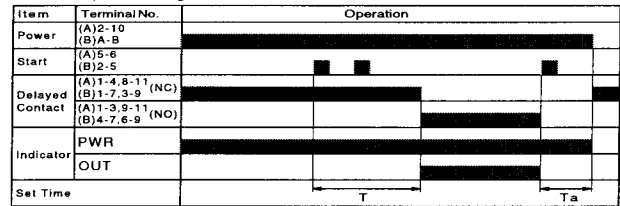

B: Cycle 2 (signal start, OFF first)

When the start input turns on while power is on, the output oscillates at a preset cycle (duty ratio 1:1), starting while the NO contact off.

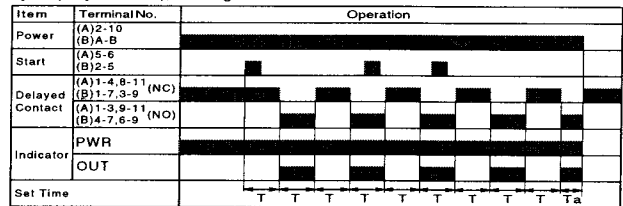

C: Cycle 4 (signal start, ON first)

When the start input turns on while power is on, the NO contact goes on. The output oscillates at a preset cycle (duty ratio 1:1).

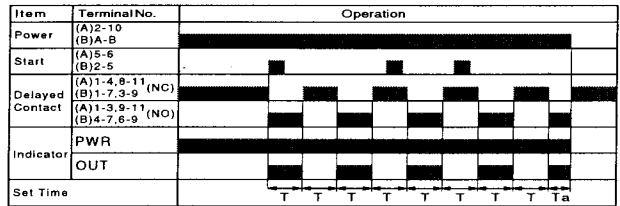

D: Signal ON/OFF-Delay

When the start input turns on while power is on, the NO output contact goes on. When a preset time has elapsed while the start input remains on, the output contact goes off. When the start input turns off, the NO contact goes on again. When a preset time has elapsed after the start input turned off, the NO contact goes off.

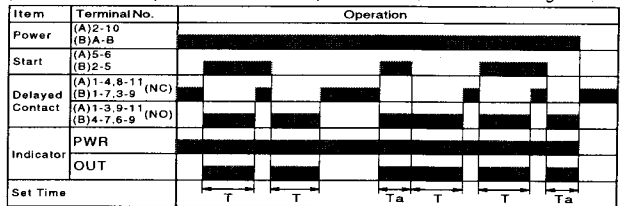

E: Signal OFF-Delay

When power is turned on while the start input is on, the NO output contact goes on. When a preset time has elapsed after the start input turned off, the NO output contact goes off.

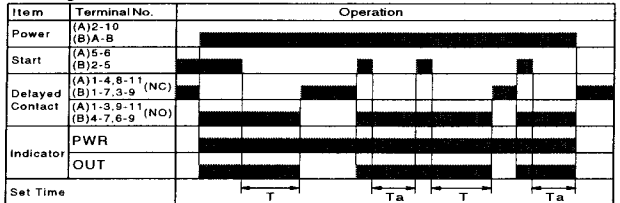

F: One-Shot (signal start)

When the start input turns on while power is on, the NO output contact goes on. When a preset time has elapsed, the NO output contact goes off.

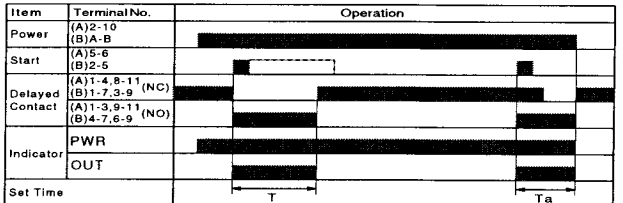

Note: T=Set Time, Ta=Shorter than set time, (1): RTE-P1, (2): RTE-B1, (A): RTE-P2, (B): RTE-B2

INTERNAL CONNECTIONS

RTE-P1

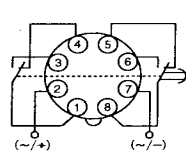

RTE-P2

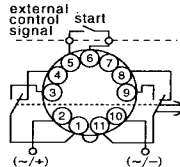

RTE-B1

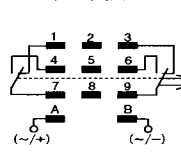

RTE-B2

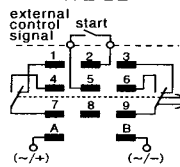

CAUTION:

RTE-P2: Do not apply voltage to terminals #5, #6 and #7.
RTE-B1, -B2: Do not apply voltage to terminals #2, #5 and #8.

NOTE: RTE series are UL Listed when used in combination with following IDEC's sockets:

RTE-P1: SR2P-06* pin type socket.

RTE-P2: SR3P-05* pin type socket.

RTE-B1, -B2: SR3B-05* blade type socket.

(*May be followed by A,B,C or U)

The socket to be used with these timers are rated:

-Conductor Temperature Rating 60°Cmin.,

-Use 14AWG max.(2mm²max.) Copper conductors only,

-Terminal Torque 9 to 12lb. ·in (1.0 to 1.3 N ·m)

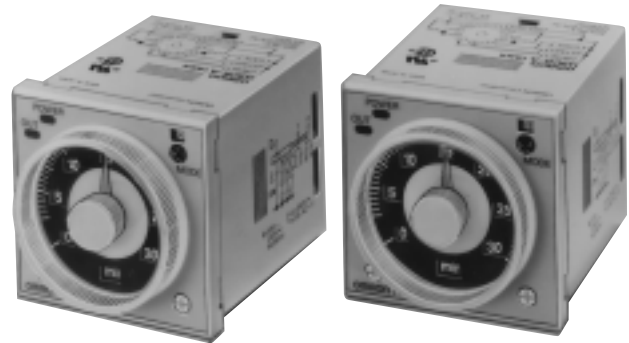

RANGE SELECTION

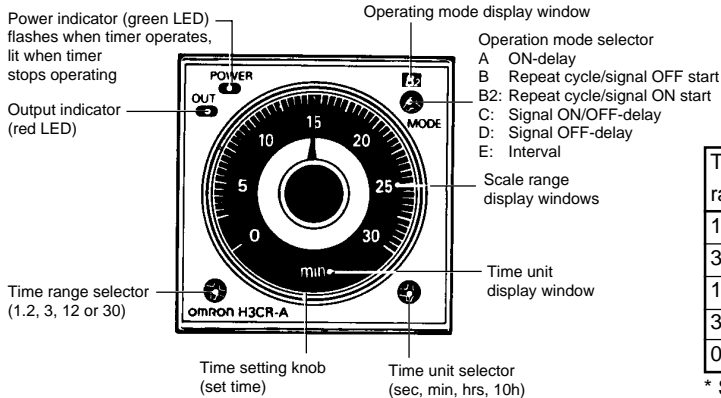

Time range	Time units			
	sec(onds)	min(utes)	hrs (hours)	10h (10 hours)
1.2	0.05 to 1.2	0.12 to 1.2	0.12 to 1.2	1.2 to 12
3	0.3 to 3	0.3 to 3	0.3 to 3	3 to 30
12	1.2 to 12	1.2 to 12	1.2 to 12	12 to 120
30	3 to 30	3 to 30	3 to 30	30 to 300
0	Instantaneous output*			

* Set to time setting knob below zero.

Specifications

Part number	H3CR-A	H3CR-AS	H3CR-A8	H3CR-A8S	H3CR-A8EL/H3CR-A8E
Supply voltage	AC 24 V or 100 to 240 VAC, 50/60 Hz				
	DC 12 V or 24 V				
Operating voltage	AC 85% to 110% of rated supply voltage				
	DC 90% to 110% of rated supply voltage at 12 VDC				
Power consumption	AC 10 VA				
	AC/DC 1.5 VA (AC), 0.8 W (DC)				
	DC 1.3 W				

Timing functions: ON-delay, Repeat cycle signal OFF start, Repeat cycle signal ON start, Signal ON/OFF delay, Signal OFF-delay, Interval

H3CR-A, H3CR-AS (SIX-FUNCTION TIMERS)

Mode A ON-Delay

Signal Start/Signal Reset

Power is applied continuously. Timing starts at the leading edge of the start input. The output relay is energized when the accumulated time equals the set time. Subsequent start signals during or after timing will not be accepted. The output relay or transistor will remain energized until a reset input is applied or power is interrupted. The minimum signal input is 0.05 second.

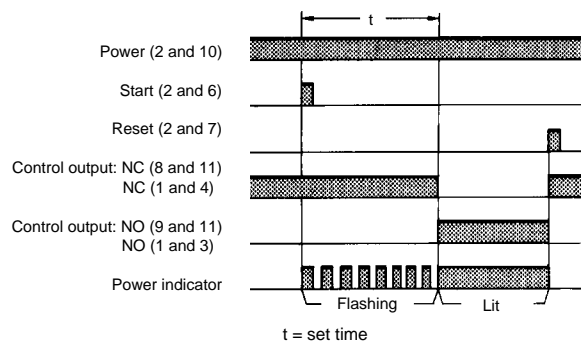
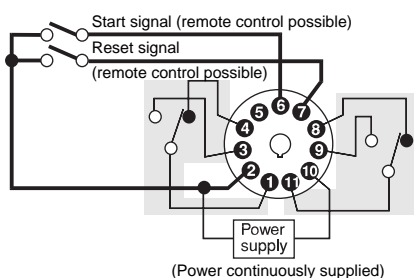

WARRANTY

J & R MANUFACTURING warrants its equipment against defective parts and workmanship under normal use and when installed in accordance with manufacturer's recommendations for a period (after date of shipment*) of twelve (12) months on parts and ninety (90) days on labor with the following provisions:

1. This warranty does not apply if problems or claims are the result of: (a) damage in transit (equipment becomes owner's property upon shipment from factory and owner must file claim with transport company); (b) misuse, neglect, improper maintenance, and or unauthorized alterations to equipment; (c) improper installation of exhaust stacks, air supply, and extraneous exhaust systems; (d) improper voltage hook-up; (e) wind, rain, hail, fire and acts of God.
2. In-warranty replacement parts will be credited only upon receipt and inspection of defective parts at the factory. All shipping charges are the responsibility of the owner, but, at the discretion of J&R Manufacturing, ground shipping charges may be waived or credited.
3. Labor to remove, replace, or repair defects under this warranty must be authorized by factory. Premium time (overtime) and travel time are not included in the warranty.
4. Sales, excise, and other taxes, food loss, and down-time are not covered under this warranty.
5. The removal of manufacturer's nameplate(s) voids the warranty.

It is the aim of J & R Manufacturing to build the finest equipment possible and to facilitate quick solutions to all problems that might arise with the lowest expense possible to the user(s). To help us achieve this goal, please follow these procedures:

1. Telephone our service department at 972-289-0801 at the first sign of a problem. Have ready the Model and Serial Number of your equipment.
2. Cooperate with our Service Department by making certain visual checks as requested. Most problems are quick and easy to pinpoint and resolve.
3. In the event it is necessary to use a service company, the factory will contact its authorized service agency. If no authorized service agency is available, please recommend a service company. The use of a service company not specifically authorized by our Service Department at factory headquarters may invalidate this warranty.

* or provable start up date, whichever is later (start up must be within 12 months of ship date)

Remember to contact J&R for any additional information you need or to order replacement parts or accessories.

Accessories include:

Ash Carts

Wood Carts

Ash Rakes

Contact J&R:

972-285-4855 (Main)

972-289-0801 (Parts and Service)

800-527-4831 (Toll Free-U.S. and Canada)

sales@jrmanufacturing.com

www.jrmanufacturing.com

